



U.S. Department of Transportation
 National Highway Traffic Safety Administration

DOT Auto Safety Hotline
Vehicle Owner's Questionnaire
 To Report Vehicle Safety Defects
 1-888-DASH-2-DOT (1-888-327-4236)
 INTERNET: www.nhtsa.dot.gov/hotline

FOR AGENCY USE ONLY 100148

Date Received 04-FEB-2009	Repository <input type="checkbox"/>
	Reference No. 10257448

OWNER INFORMATION (Type or Print)

Name	Daytime Telephone Number	E-mail Address
Address	Evening Telephone Number	
City WESLACO	State TX	Zip Code

Do you authorize NHTSA to provide a copy of this report to the manufacturer of your vehicle? YES NO
 In the absence of a signature, provide your name or address to the vehicle manufacturer.
 Signature of Owner _____ Date 2/13/09

VEHICLE INFORMATION

17 digit Vehicle Identification Number Located at bottom of windshield on driver's side <u>4U2AAHBV73C</u>	Make <u>RU Coach New mar</u>	Model <u>STAR COUNTRY</u>	Model Year <u>2003</u>
Date Purchased <u>5/20/2003</u>	Dealer's Name and Telephone Number <u>New mar Corp 574-773-7791</u>	Engine: No: Cylinders <u>6</u>	Fuel Type: <u>Diesel</u>
Original Owner <input checked="" type="checkbox"/>	Dealer's City <u>PO Box 30, Nappeance, IN</u>	State <u>IN</u>	Zip Code <u>46550</u>
Transmission Type <u>Allison</u>	<input checked="" type="checkbox"/> Antilock Brakes <input checked="" type="checkbox"/> Cruise Control	Powertrain <u>300 Cumins</u>	Multiple Failure: <u>refrigerator</u>
			Incident Date(s) <u>20-JAN-2009</u>

FAILED COMPONENT(S)/PART(S) INFORMATION

Failure Mileage	Failure Speed
-----------------	---------------

ADDITIONAL ITEMS TO BE COMPLETED WHEN REPORTING A TIRE FAILURE

Tire Make	Tire Model (Name or Number)	Tire Size (Example P215/65R15)
DOT No. (Example: DOTM9ABC036)	<input type="checkbox"/> Original Equipment <input type="checkbox"/> Prior Repair	Failure Location:
Tire Component Code	Tire Failure Type:	

ADDITIONAL ITEMS TO BE COMPLETED WHEN REPORTING A CHILD SEAT FAILURE

Make:	Date Manufactured:	Model No./Name:
Seat Type:	Installation System:	
Child Seat Component Code:	Failed Part:	

APPLICABLE INCIDENT INFORMATION

(Please describe in detail the incident(s), Failure(s), Crash(es), and injury(ies).)

Crash <input type="checkbox"/> Yes <input checked="" type="checkbox"/> No	Fire <input type="checkbox"/> Yes <input checked="" type="checkbox"/> No	Number of Persons Injured 0	Number of Deaths 0	Reported to Police N
--	---	--------------------------------	-----------------------	-------------------------

Narrative Description of Incident(S), Crash(es), and Injury(ies).
 Please describe (1) events leading up to the failure, (2) failure and its consequences, and (3) what was done to correct the failure; i.e. parts repaired or replaced (and if old part is available).

TL*THE CONTACT OWNS A 2003 NEW BAR COUNTRY COACH. THE VEHICLE HAS A DOMETIC REFRIGERATOR, MODEL NDR1062, WHICH IS INCLUDED IN A RECALL. THE CONTACT RECEIVED A RECALL NOTICE IN AUGUST OF 2008 AND A CRACK IN THE BOILER TUBE WAS REPAIRED. IN JANUARY OF 2009, THE REFRIGERATOR FAILED AGAIN. THE CONTACT PURCHASED NEW PARTS FOR THE REAR OF THE UNIT IN ORDER TO REPAIR IT HIMSELF. HE RECEIVED ANOTHER RECALL NOTICE ON JANUARY 27, 2009 AND CALLED DOMETIC REGARDING REIMBURSEMENT. HE WAS INFORMED THAT AFTER APRIL OF 2008, NO REIMBURSEMENT WOULD BE PROVIDED FOR SELF-REPAIRS. THE PART NUMBER WAS UNKNOWN.

Include, if available: Police/Fire Department Report, Photos, and Repair Invoice. ATTACH ADDITIONAL SHEETS IF NECESSARY

The Privacy Act of 1974-Public Law 93-579 This information is requested pursuant to authority vested in the National Highway Traffic Safety Act and subsequent amendments. You are under no obligation to respond this questionnaire. Your response may be used to assist the NHTSA in determining whether a Manufacturer should take appropriate action to correct a safety defect. If the NHTSA proceeds with administrative enforcement or litigation against a manufacturer, your response, or a statistical summary thereof, may be used in support of the agency's action.

U.S. Department
of Transportation
National Highway
Traffic Safety
Administration

Garland TX _____
Summer Address
4/15-11/15

Weslaco, TX _____
Winter Address
11/15-4/15

Dear Traffic Safety Administration.

February 12, 2009

In regards to a reference #10257448.

I received a recall letter on a Dometic refrigerator in my (coach) RV motor home. When I received the letter I had the recall fixed in August 2008, at an authorized dealer and, Dometic paid for the repairs. In January 2009 the boiler tube cracked and leaked out the ammonia which can start a fire or an explosion, the good part is we were not in the (coach) motor home. The recall (is on the boiler tube which can crack and cause a fire or an explosion), that would cause damage to the coach or may cause serious health problems.

I took it to an authorized NewMar coach dealer and had it repaired, the cost was over \$1394.49 dollars.

After the repairs were made I received another recall letter. I called Dometic and they said they would not pay for the bill because it was to late. I told Dometic that in their letter it states that if the boiler tube cracked before I received this last letter they would pay for the repairs. They now say it happened after April 2008. If this is so, why did they pay for the repairs in August 2008, which is after April 2008? I hope this letter can help solve this matter.

Thank you, |



*This is The one Dometic
sent to me After I called Them.*

RE: Dometic Refrigerator Recall

Dear Valued Customer:

This notice is sent to you in accordance with the requirements of the National Highway Traffic and Motor Vehicle Safety Act.

Dometic Corporation has decided that a defect which related to motor vehicle safety exists on some of the refrigerators that it manufactured between April 1997 and May 2003 for installation in recreational vehicles.

The Problem:

A fatigue crack can develop in the boiler tube of the identified refrigerators, which can permit the release of pressurized coolant solution. If this solution is exposed to an ignition source under certain specific circumstances, it can result in a vehicle fire.

Affected Units:

The potentially affected refrigerators have the following model numbers:

~~NDR1062~~, RM2652, RM2662, RM2663, RM2852, RM2862, RM3662, RM3663, RM3862, RM3863

The possibly affected units have serial numbers beginning with the following combinations:

713xxxxx through 752xxxxx

801xxxxx through 852xxxxx

901xxxxx through 952xxxxx

001xxxxx through 052xxxxx

101xxxxx through 152xxxxx

201xxxxx through 252xxxxx

301xxxxx through 319xxxxx

If you own one of the above units, it requires immediate service and continuing use could pose a potential safety hazard.

How Do I Know If My Refrigerator Is Being Recalled?

- 1) Find your refrigerator's model and serial numbers by opening the refrigerator door and looking for the sticker attached to the side wall of the interior. See the photo instructions included in this mailing for the exact location of the sticker.
- 2) Call 1-888-446-5157 or go to www.DometicUSA.com to confirm if your refrigerator is affected by the recall.

Dometic Corporation • PO Box 490 • Elkhart, IN 46515
Phone 574-294-2511 • Fax 574-293-9686
www.dometicusa.com

DOMETIC CORPORATION REFRIGERATORS PRE-NOTIFICATION REIMBURSEMENT PROGRAM

Dometic Corporation (Dometic) is recalling certain refrigerators manufactured between April 1997 and May 2003 for installation in recreational vehicles in order to remedy a defect that can cause a fire under certain specific circumstances. The manufacturers of vehicles in which the recalled refrigerators were installed as original equipment are also conducting recalls of those vehicles to address that defect.

An owner of a vehicle equipped with a recalled refrigerator who incurred costs before this recall to remedy this defect is entitled to reimbursement, subject to the limitations and qualifications noted below. Dometic will reimburse such owner the dollar amount paid for the remedy, including labor at local rates and associated costs such as taxes and disposal fees.

Time Limitation:

To be covered, the pre-recall repair must have occurred no earlier than August 28, 2005.

This Date was made up after I called them.

Exclusions:

Dometic's program does not include reimbursement:

- (a) for costs incurred while our original warranty was in effect and would have provided a free remedy (without any consumer payment) of the problem involved in the recall, unless an authorized dealer or representative denied warranty coverage to you or the warranty repair did not remedy the problem involved in the recall;
- (b) for a pre-notification remedy that did not address the defect involved in the recall;
- (c) for a pre-notification remedy that was not reasonably necessary to correct the defect involved in the recall;
- (d) for insufficient documentation of your claim for pre-notification reimbursement, as described below. If this is the case, you will be given an opportunity to resubmit the claim with the complete information.
- (e) Incidental or consequential damages to personal property.

Required Claim Documentation:

In order to process your claim, you must provide Dometic with the following information and documentation:

- (a) your name and mailing address;
- (b) the model and serial number of recalled refrigerator;
- (c) the make, model, model year and vehicle identification number of your vehicle;
- (d) a copy of the receipt for the pre-notification remedy, which identifies parts involved and states the total amount paid; and
- (e) if the pre-recall remedy was obtained when it could have been remedied at no charge under warranty, documentation indicating that an authorized representative either refused or failed to remedy the recall problem under the warranty program.

Where to file:

Claims for reimbursement with the required documentation as described in this Program should be mailed to:

**Dometic Warranty Department
2320 Industrial Parkway
Elkhart, IN 46516**

If you have any questions about this reimbursement program, please call 1-888-446-5157.

**DOMETIC CORPORATION REFRIGERATORS
PRE-NOTIFICATION REIMBURSEMENT FORM**

First and Last Name

Street Address

Duluth Mn _____
City State Zip Code

Telephone

VEHICLE INFORMATION

2003 Newmar Kountry Star
Year Make Model

4U2AAHBV734
Vehicle Identification Number

REFRIGERATOR INFORMATION

1062 _____
Model Number of Recalled Unit Serial Number of Recalled Unit

1. Did you obtain the pre-notification remedy when it could have been remedied at no charge under warranty, but our representative either refused or failed to remedy the recall problem under our warranty program?

Yes No:

If you checked "Yes" you must provide documentation with your submission reflecting such refusal.

2. You must provide a copy of the receipt for the pre-notification remedy, identifying the parts involved and that stating the total amount paid.

3. Any payment made under the Dometic Corporation Pre-notification Refrigerator Reimbursement Program is not an indication that Dometic Corporation believes that such repairs were in fact needed, and does not constitute a warranty that such repairs were properly performed; and Dometic Corporation expressly disclaims any such warranty express or implied.

Please return this completed form with required documentation to:

**Dometic Warranty Department
2320 Industrial Parkway
Elkhart, IN 46516**

What To Do:

1) Turn the refrigerator off immediately if you notice any of the following indicators:

- Leakage or staining at the back of the refrigerator.
- Yellow residue at the back or sides of the refrigerator.
- The smell of ammonia.
- Refrigerator does not properly cool.

Any unit found to have one or more of the characteristics mentioned above MUST be shut down and not operated until the unit is fixed and the recall rework administered.

For any unit that does fall within the recall population, but does not exhibit any of the four indicators mentioned in #1, consider the following:

- 2) Do not operate your refrigerator on LP gas. Switching to electric power lowers the incident rate associated with LP gas. If you own a 3-way refrigerator, running the unit on 12-volt power carries the least risk of all. 3-way refrigerators have model numbers that end in "3".

Dometic recommends that the unit not be operated on electric unless absolutely necessary until your unit has been serviced. **If you choose to operate your unit on electric prior to the recall rework, you must inspect the burner area weekly for any of the indicators referenced in number 1 above.**

- 3) Dometic recommends that you turn off the gas valve at the back of your refrigerator. **DO NOT**, however, attempt to disconnect the gas supply. Instructions on how to turn off the gas valve are included in this envelope.
- 4) If you must operate your refrigerator on electric, **DO NOT** operate your refrigerator while in transit or while occupants are asleep.
- 5) The rework kit will be available on April 16, 2007. At that time, call your preferred service center to set up an appointment. For help in locating a service center, or for the most up-to-date recall information, call 1-888-446-5157.

Please do not simply go to a dealer or service center without an appointment, since some facilities will not be performing this work, and the ones that are doing the work will need to obtain the appropriate parts from us. Please bring this letter with you at the time of your scheduled service.

- 6) If the repair facility fails or is unable to rework this noncompliance without charge and within a reasonable time, please contact us at the number provided above so we can attempt to resolve the problem. You may also submit a written complaint to the Administrator, National Highway Traffic Safety Administration, 400 Seventh Street, SW, Washington, DC 20590; or call the toll-free Vehicle Safety Hotline at 1-888-327-4236 (TTY: 1-800-424-9153); or go to <http://www.safercar.gov>.

- 7) If you previously paid to repair or replace a Dometic refrigerator that failed due to this defect, you can be reimbursed for your costs pursuant to Dometic's Pre-Notification Reimbursement Program. To be eligible for reimbursement under that Program, you must complete and submit the required form and provide the necessary documentation. The Program and form can be obtained by calling 1-888-446-5157.

If You No Longer Own This Refrigerator:

If you are no longer the owner of the affected refrigerator, we would greatly appreciate you furnishing us with the name and address of the new owner by calling 1-888-446-5157.

You May Receive More Than One Mailing In Regards To The Recall:

To reach as many customers as possible, Dometic and the original manufacturer of your RV will each send notifications in regards to this recall. Be advised that though you may receive multiple notifications, all pertain to this same, single recall.

On a Personal Note:

We sincerely apologize for any inconvenience this may cause. We are continually committed to developing innovative products to meet your needs and enhance your RV travels, keeping your safety at the top of our priority list.

Patrick N. McConnell
Director of Engineering, Product Safety and Standards
Dometic Corporation

RECALL 06E-076

! **IMPORTANT**
Dometic Recall Information

SERIAL NUMBER/GAS VALVE INSTRUCTIONS

RECALL 06E-076

Where to find the serial and model numbers on your Dometic refrigerator

The serial and model numbers are both located on a sticker inside the fridge door. *It could be on either side of the interior.*

Remember, the model number starts with RM or NDR, and the serial number is 8 digits long.

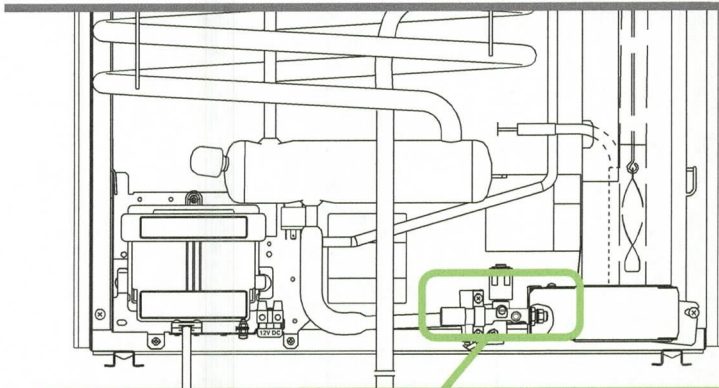

How to close the gas valve on your Dometic refrigerator

The manual gas valve is located at the back of your refrigerator near the floor as seen in the diagram to the left. Access the back of your refrigerator by removing the vent on the side of your coach. The vent will look like one of the two following illustrations:

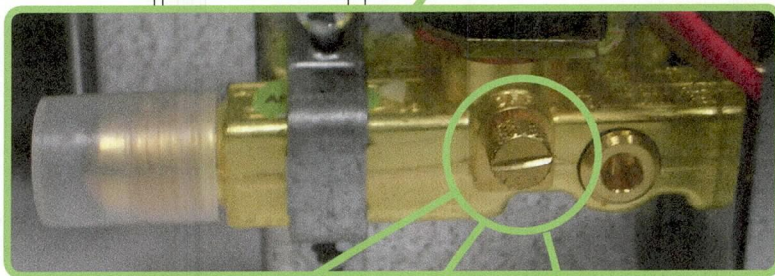
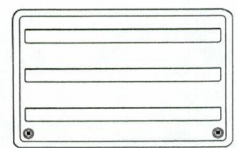
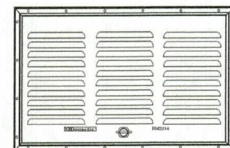

Open



Turn Clockwise



Closed

The gas valve is opened and closed by adjusting a screw. To close the valve, use either your fingers or a flat-head screwdriver to turn the screw 1/4 turn clockwise.

The valve is closed if the flathead slot in the screw runs up and down. The valve is still open if the flathead slot in the screw runs side to side.

RON HOOVER CO. OF DONNA, INC
101 EXPRESSWAY 83
DONNA TX
US
78537
956-464-4403

CUSTOMER WORK ORDER # 8000

Completed: 16 JAN 09 Customer: _____
Invoice #: 088404 Address: _____
Author: VC-DH-RRR GARLAND TX
Stock No: _____
Year/Make: 2003 MA NEWMAR KOUNTRY Home Phone: _____
Model: Work Phone: _____
Serial No: Purchase Date: _____
Chassis No: 4UZAABDV73C Date In: 12 JAN 09
Mileage: 50463 Promise Date: _____
Key No: 5430 Schedule Date: _____
Location: IH License No: _____
Reqn No: Trim: _____
Warr. Date: Promise Time: _____
Print Date: 16 JAN 09

Job # Description JOB INFORMATION

1 COMPLAINT: CUSTOMER REQUEST WE CHECK FRIDGE IT IS
INOP YELLOW STUFF ALLOVER COOLING TUBES
CAUSE: WAS NO GOOD
CORRECTION: REMOVED FRIDGE AND COOLING UNIT.
INSTALL NEW COOLING UNIT AND REASSEMBLE
FRIDGE. NOTE FRIDGE HANDLES ARE GLUED
TOGETHER . TEST WORKING FINE
2 COMPLAINT: CUSTOMER REQUESTED IF WE HAVE TIME TO
CHECK KVH SAT. NOT WORKING PROPERLY.
CAUSE: COULD NOT CHECK KVH SAT.
CORRECTION:
3 COMPLAINT: CUSTOMER STATE CHECK INVERTOR INOP. TO
CHECK SWITCH.
CAUSE: INOP.
CORRECTION: CHECKED THE INVERTOR AND ITS WORKING
PROPERLY. THIS INVERTOR IS A LITTLE ONE
AND ONLY RUNS THE TV. CUSTOMER HAS BEEN
NOTIFY ABOUT THIS.
4 COMPLAINT: DOMETIC RECALL
CAUSE: NEEDED
CORRECTION: AFFECTED. SO INSTALL RECALL KIT AS PER
DOMETIC.
5 CUSTOMER PAYS THE LABOR ON JOB 1
6 COOLING UNIT NOT UNDER WARRANTY

Part No	Job#	Description	PARTS	Qty	Price	Total
2934806106	6	COOLING UNIT		1.00	942.11	942.11
3311266.000	4	BURNER KIT HOUSING		1.00	W	-N/C-

Continued on page 2

Work Order : 8000

```
*****
Job #          Total      LABOUR
*****
  4            -N/C-
  5            358.00
*****
```

```
*****
Excode  Job#  Description      EXTRAS      Qty      Price      Total
*****
SST      2    SHOP SUPPLIES - TAXABLE      1.00     17.90     17.90
FRTN     6    FREIGHT - NON TAXABLE      1.00     75.00     75.00
*****
```

CUSTOMER COMMENTS

```
*****
FECH WILL CHECK AND GET NUMBERS WE WILL CALL IT IN TO SEE IF
UNDER WARRANTY WILL ADVISE
COOLING UNIT ORDERED WILL BE IN ON THURSDAY THE 15TH CUSTOMER
HAS A DEPOSIT VINCE
D6015 IS THE PO FOR THE COOLING UNIT. (JS)
*****
```

```
Parts Total:      942.11
Labour Total:     358.00
Sublet Total:      0.00
Extras Total:      92.90
Tax Total:         1.48
Work Order Total: 1,394.49
```

Customer Signature: _____

Date: 22 JAN 2009

The above said vehicle has been received as promised. I have inspected the condition of my unit and found it to be satisfactory inside and outside. After careful inspection of work performed and materials furnished, both the work performed and materials used were found to be satisfactory. I understand there is a 60 day warranty on any labor performed and the warranty on the parts used is backed by the manufacturer of the part.

Signature: _____

Date: 1/22/9

~~1~~
Date Received

1/27/9

NDR 1062

S.N. 237-00023

Called Dometic

on 1/29/9

will send out Form

Custom Id

NEWMAR

Called Dometic

2/4/9

alice

I do not

have a copy

of the 1st

Recall

Letter

This is The

2nd Recall.

Subject: Newmar Dometic Refrigerator Recall
NHTSA Recall # 07V-075

Dear Valued Customer:

This notice is sent to you in accordance with the requirements of the National Traffic and Motor Vehicle Safety Act.

REASON FOR THIS RECALL

Newmar has decided that a defect which relates to motor vehicle safety exists in certain vehicles it manufactured equipped with Dometic refrigerators. This decision was based on information provided by Dometic Corporation that a defect exists in some of the refrigerators that Dometic manufactured between April 1997 and May 2003 for installation in recreational vehicles. Newmar installed these refrigerators in recreational vehicles that it manufactured from April 1997 to May 2003.

The Problem:

A fatigue crack can develop in the boiler tube of the identified refrigerators, which can permit the release of pressurized coolant solution. If this solution is exposed to an ignition source under certain specific circumstances, it can result in a vehicle fire.

Affected Units:

The potentially affected refrigerators have the following model numbers:

NDR1062, RM2652, RM2662, RM2663, RM2852, RM2862, RM3662, RM3663, RM3862, RM3863

The possibly affected units have serial numbers beginning with the following combinations:

713xxxxx through 752xxxxx

801xxxxx through 852xxxxx

901xxxxx through 952xxxxx

001xxxxx through 052xxxxx

101xxxxx through 152xxxxx

201xxxxx through 252xxxxx

301xxxxx through 319xxxxx

If you own one of the above units, it requires immediate service and continuing use could pose a potential safety hazard.

WHAT WE WILL DO

Newmar in cooperation with Dometic, will provide owners of all covered refrigerators a rework for the potential defect at no charge for parts or labor. The rework consists of secondary burner housing, a thermal fuse and a melt fuse.

WHAT YOU SHOULD DO

How Do I Know If My Refrigerator Is Being Recalled?

- 1) Find your refrigerators' model and serial numbers by opening the refrigerator door and looking for the sticker attached to the side wall of the interior. See the photo instructions included in this mailing for the exact location of the sticker.
- 2) Call **1-888-446-5157** or go to **www.DometicUSA.com** to confirm if your refrigerator is affected by the recall.

What to Do:

- 1) **Turn the refrigerator off immediately if you notice any of the following indicators:**
 - Leakage or staining at the back of the refrigerator.
 - Yellow residue at the back or sides of the refrigerator.
 - The smell of ammonia.
 - Refrigerator does not properly cool.

Any unit found to have one or more of the characteristics mentioned above MUST be shut down and not operated until the unit is fixed and the recall rework administered.

For any unit that does fall within the recall population, but does not exhibit any of the four indicators mentioned in #1, consider the following:

- 2) Do not operate your refrigerator on LP gas. Switching to electric power lowers the incident rate associated with LP gas. If you own a 3-way refrigerator, running the unit on 12-volt power carries the least risk of all. 3-way refrigerators have model numbers that end in "3".

Dometic recommends that the unit not be operated on electric unless absolutely necessary until your unit has been serviced. **If you choose to operate your unit on electric prior to the recall rework, you must inspect the burner area weekly for any of the indicators referenced in number 1 above.**

- 3) Dometic recommends that you turn off the gas valve at the back of your refrigerator. **DO NOT**, however, attempt to disconnect the gas supply. Instructions on how to turn off the gas valve are included in this envelope.
- 4) If you must operate your refrigerator on electric, **DO NOT** operate your refrigerator while in transit or while occupants are asleep.

~~NR~~ NDR 1062
237-00023

- 5) The rework kit is available. Please call your preferred service center to set up an appointment. For help in locating a service center, or for the most up-to-date recall information, call 1-888-446-5157.

Please do not simply go to a dealer or service center without an appointment, since some facilities will not be performing this work, and the ones that are doing the work will need to obtain the appropriate parts from us. Please bring this letter with you at the time of your scheduled service.

- 6) If the repair facility fails or is unable to rework this noncompliance without charge and within a reasonable time, please contact us at the number provided above so we can attempt to resolve the problem. You may also submit a written complaint to the Administrator, National Highway Traffic Safety Administration, 1200 New Jersey Avenue, SW, Washington, DC 20590; or call the toll-free Vehicle Safety Hotline at 1-888-327-4236 (TTY: 1-800-424-9153); or go to <http://www.safercar.gov>.

- 7) If you previously paid to repair or replace a Dometic refrigerator that failed due to this defect, you can be reimbursed for your costs pursuant to Dometic's Pre-Notification Reimbursement Program. To be eligible for reimbursement under that Program, you must complete and submit the required form and provide the necessary documentation. The Program and form can be obtained by calling 1-888-446-5157. *They would not send out the forms*

If You No Longer Own This Recreational Vehicle:

If you are no longer the owner of the recreational vehicle, we would greatly appreciate you furnishing us with the name and address of the new owner by calling 1-888-446-5157.

You May Receive More Than One Mailing In Regards To The Recall:

To reach as many customers as possible Newmar and Dometic will each send notifications in regards to this recall. Be advised that though you may receive multiple notifications, all pertain to this same, single recall.

Your safety and satisfaction with your Newmar product are important to us and we regret any inconvenience to you.

Sincerely,

Newmar