

CL-10226154-4704



RECEIVED
100-211

2008 APR 21 P 2 03

OFFICE OF THE ATTORNEY GENERAL
STATE OF ILLINOIS

Lisa Madigan
ATTORNEY GENERAL

April 14, 2008

NHSTA Headquarters
National Highway Traffic Safety Administration
1200 New Jersey Ave. S.E.
West Building
Washington, DC 20590

Re: Gillespie Pontiac
File No: _____

Dear Sir/Madam:

The Consumer Protection Division of the Attorney General's office has received a complaint concerning a company which appears to fall under your jurisdiction. A copy of the complaint is enclosed for your review.

Thank you for your cooperation and assistance.

Sincerely,

Daniel Ligocki

Daniel Ligocki
Citizen's Advocate
Consumer Protection Division
(312) 814-3866

enclosure
/drf

NM
4/21/08
3:17
CW



LISA MADIGAN

Illinois Attorney General
 Consumer Fraud Bureau
 500 South Second Street
 Springfield, IL 62706
 217-782-1090
 1-800-243-0618 (Toll free in IL)
 CHICAGO OFFICE

Office Use Only
 CLMS: 214845
 AG: _____

APR 07 2008
 RECEIVED
 APR 04 2008
 OFFICE OF THE ATTORNEY GENERAL

CONSUMER FRAUD
 CHICAGO
 www.IllinoisAttorneyGeneral.gov

Fill out the form online, then print and mail to the address above. Include copies (no originals please) of any supporting documents.

YOUR INFORMATION: **NAME OF SELLER OR PROVIDER OF SERVICE:**

Name: Mr., Mrs., Ms. (circle one) [REDACTED]	Name: GILLESPIE PONTIAC GREATER CHICAGO AUTO SALES Inc
Address: [REDACTED]	Address: 6603-33 SOUTH WESTERN AVENUE
City: CHICAGO, IL State: [REDACTED] Zip code: [REDACTED] County: [REDACTED]	City: CHICAGO, IL State: IL Zip code: 60636
Your Telephone Number: Daytime [REDACTED] Evening [REDACTED]	Telephone (773) 434-8200 Website:
Your e-mail address (optional):	Additional seller or provider of service involved in transaction: Name: SCOTT LAWSON - GM PONTIAC
Are you a senior citizen? Yes <input type="checkbox"/> No <input checked="" type="checkbox"/>	Address: PO BOX33172 City: DETROIT, MI 48232-5172 State: MI Zip code: 48232-5172
Who referred you to this office?	Telephone (800) 620-7668 Website:

Has this matter been submitted to another government agency, an arbitration service, or to an attorney? Yes No
 If yes, please give name, address, telephone number # _____
 Is court action pending? Yes No

INFORMATION ABOUT THE TRANSACTION

Date of Transaction: JULY 2001 (Purchased) **Did you sign a contract?** Yes No **Date contract was signed:** July 2001
 (If yes, please attach a copy)

Was the product or service advertised? Yes No When? _____ (Please attach a copy of the advertisement, if available)

<p>How was the service advertised?</p> <ul style="list-style-type: none"> <input checked="" type="checkbox"/> • Newspaper/magazine <input type="checkbox"/> • Radio advertisement <input checked="" type="checkbox"/> • Television advertisement <input type="checkbox"/> • Internet advertisement <input type="checkbox"/> • E-mail solicitation <input checked="" type="checkbox"/> • Direct mail solicitation <input type="checkbox"/> • Telephone solicitation <input type="checkbox"/> • Yellow pages of the telephone book <input type="checkbox"/> • Facsimile solicitation <input type="checkbox"/> • Door-to-door solicitation <input type="checkbox"/> • Display at merchant's place of business <input type="checkbox"/> • Display at a trade show/convention, etc. <input checked="" type="checkbox"/> • Other LETTER MARCH 2008 	<p>Total Cost of product/service: \$ 34,000 (est)</p> <p>Amount paid to date/down payment: \$ 34,000 (est)</p> <p>Method of payment (check one) (Please attach a copy) Cash <input checked="" type="checkbox"/> Check <input checked="" type="checkbox"/> Money Order <input type="checkbox"/> Credit Card <input type="checkbox"/> Debit Card <input type="checkbox"/> Bank Draft <input type="checkbox"/> Wire Transfer <input type="checkbox"/> Automatic Debit <input type="checkbox"/> Other _____</p> <p><i>If you paid with a credit card, have you contacted your credit card company to register a dispute?</i> Yes <input type="checkbox"/> No <input type="checkbox"/></p> <p><i>(Under the Federal Fair Credit Billing Act, you have 60 days from the time that you receive your statement to dispute the charge.)</i></p>
--	---

Where did the transaction take place?

- At my home
- Over the telephone
- By mail
- Over the Internet
- Trade show/convention/home show
- ✓ At the firm's place of business
- By facsimile
- Other (please specify) _____
- There was no transaction

Have you complained to the company or individual?

Yes No

If yes, provide name and phone number of the individual(s):

Called 800 # and spoke with Supervisor Laura - she

offered no solutions; hundreds of prior discussions

with GM/Pontiac/Gillespie personnel (see attached)

FOR COMPLAINTS REGARDING MOTOR VEHICLES, PLEASE COMPLETE THIS BOX:

Make: PONTIAC	Model: GrandPrix GTP	Year: 2001	New: Yes <input checked="" type="checkbox"/> No <input type="checkbox"/>	As-Is: Yes <input type="checkbox"/> No <input checked="" type="checkbox"/>
Warranty: Yes <input checked="" type="checkbox"/> No <input type="checkbox"/>	Name of Extended Warranty: GM-Pontiac	Purchase Date: July 2001	Current Mileage: 73,000	Mileage at Purchase: 6,000 (dealer demo)
Expiration Date: July 2006				

Briefly describe the transaction and your complaint. You may use additional sheets if necessary. **Please attach copies of all contracts, letters, receipts, cancelled checks (front and back), advertisements, or any other documents that relate to your complaint. PLEASE DO NOT SEND ORIGINALS.**

GILLESPIE PONTIAC FAILED TO ADDRESS OIL LEAKS AND ON INFORMATION AND BELIEF, BASED UPON SUBSEQUENT DEALERSHIP'S MANAGER'S STATEMENT AND SIGNIFICANT REPAIR HISTORY, THE CAR WAS IN A MAJOR FRONT END COLLISION WHICH GILLESPIE CONCEALED FROM ME.

PONTIAC-GM IS ENDANGERING MY LIFE AND THOSE OF MANY ILLINOIS RESIDENTS WITH ITS DEFECTIVELY DESIGNED AND DANGEROUS 2001 PONTIAC GRAND PRIX GTP. THIS CAR IS A KNOWN FIRE HAZARD, AND CAN SPONTANEOUSLY START ON FIRE AND EXPLODE, AS ADMITTED BY SCOTT LAWSON IN HIS LETTER TO ME DATED MARCH 2008 (SEE ATTACHED).

THE PONTIAC GTP IS UNSAFE AT ANY SPEED. IT IS MORE DANGEROUS THAN A PINTO, SINCE IT DOES NOT EVEN NEED AN IMPACT TO CATCH FIRE AND EXPLODE.

PONTIAC OFFERED NOTHING TO PROTECT ME OR ILLINOIS RESIDENTS IN THE VICINITY OF THIS CAR. I AM REALLY DISAPPOINTED IN THE SHODDY QUALITY, THE COUNTLESS WARRANTY REPAIR VISITS THAT I HAVE SUFFERED THROUGH, AND NOW THIS CLEAR AND PRESENT DANGER.

I WOULD LIKE PONTIAC TO PAY ME AND ALL ILLINOIS RESIDENTS WHO OWN A PONTIAC GTP THE ORIGINAL PURCHASE PRICE, LESS THE CURRENT RESALE VALUE, AND TAKE POSSESSION OF THIS CAR, SO I DO NOT HAVE TO LIVE WITH THE FACT THAT MY CAR COULD SPONTANEOUSLY CATCH FIIRE AND POTENTIALLY HARM OTHERS.

Also - I AM UNABLE TO SELL THIS VEHICLE NOW!

What form of relief are you seeking? (E.g. exchange, repair, money back, product delivery, etc.)
 RETURN OF PURCHASE PRICE FOR FRAUDULENT SALE IN EXCHANGE FOR TAKING THIS PINTO OFF MY HANDS.

READ THE FOLLOWING BEFORE SIGNING BELOW:

In filing this complaint, I understand that the Attorney General is not my private attorney, but rather enforces laws designed to protect the public from misleading or unlawful business practices. I also understand that if I have any questions concerning my legal rights or responsibilities, I should contact a private attorney. I have no objection to the contents of this complaint being forwarded to the business or the person the complaint is directed against, unless box checked below. The above complaint is true and accurate to the best of my knowledge.

Signature: _____



Date: 3.5.1.08

- • Check here if you only want to notify our office of your concerns and do not want a mediation process initiated.

Please print and send the completed form to the address at the top of this complaint form. Incomplete forms may be returned.



GM

Important Safety Notice

March 2008

Chicago, IL

Dear :

Part of our commitment to you is providing important information whenever a specific concern or problem may affect your vehicle.

GM will soon announce a safety recall to correct an issue that may cause a fire in your 2001 model year Pontiac Grand Prix with the 3.8L supercharged engine.

The purpose of this letter is to explain this issue, what GM is doing to correct it, and what you can do immediately to reduce the potential for injury.

We believe that the fires may be caused by drops of engine oil being deposited on the exhaust manifold through hard braking. If the manifold is hot enough and the oil runs below the heat shield, it may ignite into a small flame and in some instances the fire may spread to the plastic spark plug wire channel. This may have occurred in about one in one thousand vehicles.

We are currently working with our suppliers to obtain sufficient parts so we can launch a full recall to address this situation.

Please know that we understand the concern this may cause and the need to correct it as quickly as we can. Until we are able to do so, there are three very important precautions you should take:

- We strongly recommend you not park your vehicle in a garage, car port, or other structure.
- If you notice a burning odor, you should have your Pontiac dealer inspect your vehicle. The dealer will inspect your vehicle without charge.
- Use premium fuel (91 octane or higher) in your vehicle, as recommended in your vehicle's owner manual.

If you have any questions or need any assistance, please call the Pontiac Customer Assistance Center between the hours of 8:00 AM and 8:00 PM, EST, Monday through Friday. It can be reached at 1.800.620.7668 (TTY 1.800.833.7668).

We are sorry to cause you this inconvenience; however, we have taken this action in the interest of your safety and continued satisfaction with our products.

LARA
SUPERVISOR

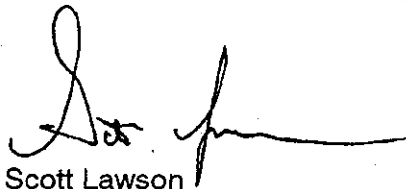

Scott Lawson
General Director,
Customer and Relationship Services



P.O. Box 33172 · Detroit, MI 48232-5172



P10400027245 J G
 Gillespie Pontiac
 6603-33 S Western Ave.
 Chicago, IL 60636

PRESORT 1PG001111 0078/0000

Chicago, IL



Dear [REDACTED]:

Thank you again for choosing a new Pontiac Grand Prix and for selecting Gillespie Pontiac as your new car dealer. We appreciate your confidence in us, and we'll continue to do all we can to deserve it.

During delivery of your new Grand Prix, you received important information about its care and maintenance and a guide to owner privileges entitled "Pontiac Cares." And in the future, we'll continue to keep you informed of timely service and maintenance procedures.

When you bring your Grand Prix in for service, you have a right to expect the consideration traditionally reserved for Pontiac owners — a tradition based on products, quality service, and complete customer satisfaction.

We want to continue that tradition by providing you with all the maintenance needed to help you protect and maintain the quality standard of your new Grand Prix. We look forward to satisfying all your service needs.

Sincerely,

Rick Lanham

Rick Lanham
 Parts/Service Director
 Gillespie Pontiac
 (773) 434-8200

P.S. Your owner's manual remains the best and most complete source of detailed information about the care and maintenance of your Grand Prix. Keep it with you wherever and whenever you drive, and again, if you have questions, don't hesitate to call us.

C U S T O M E R C A R E — P O N T I A C S T Y L E

**3000 Mile First Oil Change FREE! Ask About Our
 New Owner Clinic. Please Return GM Survey. Call
 If Not Completely Satisfied**

Gillespie Pontiac
6603-33 S Western Ave., Chicago, IL 60636

"It's Another Great Day At Gillespie Pontiac"

Hours Open:
 Mon, Wed and Fri 7:00 AM - 6:00 PM
 Tuesday and Thursday 7:00 AM - 9:00 PM
 Saturday 8:00 AM - 2:00 PM

Credit Cards Honored:
 MasterCard, VISA, Diners Club, Discover, Carte
 Blanche, American Express

2001 Grand Prix
 1G2WR12161F145736
 07/30/2001

September 24, 2001

Hand Delivered

Jerry Mitre
Service Consultant
Gillespie Pontiac Greater Chicago Auto Sales, Inc.
6603 South Western Avenue
Chicago, Illinois 60636-2412

Re: 2001 Pontiac Grand Prix GTP
Purchased at Gillespie Pontiac 7/30/01 (Demo Vehicle)
VIN 1G2WR12161F

Dear Jerry:

Thanks for rescheduling the appointment from Saturday 9/22 to 7:00 a.m. on Monday 9/24 and agreeing to provide a loaner vehicle. I am writing this letter to you and Pontiac/GM just to confirm problems experienced with the above new vehicle, and as requested by Pontiac/GMC in the Warranty & Owner Assistance Manual (pgs. 27-28) addressing Warranty Enforcement Laws.

Since owning this new car for a little over a month, two major problems surfaced. In addition to warranty enforcement law issues, these problems also raise the question of whether this vehicle was in an accident while Gillespie Pontiac's managers drove this car as a "demo" vehicle.

A. ENGINE OIL LEAK

During an oil/filter change at about 7,000 miles, an oil leak was noticed around one of the bolts securing the intake manifold (passenger side top/front), which you observed and confirmed. I have not inspected every bolt, or every gasket on the engine/transmission, and am concerned that there may be additional leaks. This leak is in plain site on the top of the engine. I am surprised that this leak was not previously noticed by Gillespie service technicians when (according to the salesman who sold this car) they changed the oil and gave it a complete inspection prior to my purchase of the vehicle. It goes without saying that this engine should not be leaking.

B. INTERIOR WATER LEAK AT PASSENGER DOOR

Second, I observed multiple water leaks coming through the passenger side door and into the interior of the car. On inspection, you confirmed that the rubber door seal was not damaged, and you stated that the leaks may be the result of door misalignment, but that the trim shop which Gillespie contracts this work to was not open on Saturdays.

Since owning this car (which was a demo vehicle at your dealership for the first 6,010 miles), I noticed water inside the passenger side carpets twice before scheduling the appointment for Saturday 9/22/01. After the appointment was scheduled, water leakage was also confirmed a third time on 9/20/01. I initially noticed the water because of an old soda/cola stain that was never cleaned before my taking possession of the car, on the rear passenger carpet.

While it was raining on 9/20, I observed water leaking where the roof and passenger door meet, above the two stereo speakers in the door, and from the rear, lower portion of the door. It seems that water is leaking into/through the door itself, and was definitely leaking onto both stereo speakers in the door.

During my short ownership of this car, the passenger side carpet was wet after every rain. I am very surprised that the Gillespie manager who drove this car for over 6,000 miles did not notice this problem, or have it corrected. I noticed the water leakage within weeks of taking possession of the car – Gillespie's manager drove it for over 6,000 miles spanning many months including winter months. The carpet is still wet today (9/24) from Thursday's and/or Sunday's rains.

My concern about these problems raises the question of whether this vehicle was previously involved in an accident, particularly in light of your comment regarding door misalignment. Please let me know if you or the Gillespie Service department have any knowledge of this car being involved an accident, or if there is any indication of repair work.

I am also concerned about secondary impacts from these two problem areas:

- (a) secondary/premature engine damage due to the oil/gasket leakage;
- (b) damage to the two stereo speakers located in the door, which were both observed to have water leaking directly over them;
- (c) electrical problems/corrosion/shorts due to water leakage;
- (d) mold/bacteria growth in the interior of the car (carpet/door), in light of which I request complete replacement of the interior floor carpet;
- (e) premature rusting/corrosion of the floor panels, doors and interior components, due to water leakage problems that seems to have existed for over 6,000 miles prior to my ownership of this vehicle;
- (f) other problems, misalignments or premature failures that were not identified prior to my taking possession of the vehicle.

Although the above problems are covered under the warranty, and you have agreed to provide the work necessary to correct them at no cost to me, I have already wasted a couple of hours bringing the vehicle to the dealership on Saturday 9/22, and will waste additional time this week dropping the car off and picking it up from the dealership, on top of not being able to use my car while it is being serviced. Nonetheless, thank you for addressing these concerns.

Sincerely,



cc: Pontiac-GMC Customer Assistance Center
PO Box 33172
Detroit, Michigan 48232-5172

CHICAGO, ILLINOIS

Pontiac-GMC Customer Assistance Center
PO-Box 33172
Detroit, Michigan 48232-5172



*** TX REPORT ***

TRANSMISSION OK

TX/RX NO 3152
CONNECTION TEL 4345906
SUBADDRESS
CONNECTION ID GILLESPIE
ST. TIME 10/05 12:03
USAGE T 02'26
PGS. SENT 3
RESULT OK

Fax Cover Sheet

kinko's®

3435 N. Western Avenue
Chicago, Illinois 60618
Tel: (773) 755-9000
Fax: (773) 755-4388

Date: 10/5/01

To: JERRY MITRE

Company: GILLESPIE PONTIAC

Fax: 773/434-5906

From: 

Company: _____

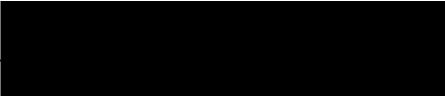
Tel: 

Number of pages including this one: 3

Comments:

JERRY - PROBLEMS REMAIN.
ALSO, NOW THAT IT'S
COOLING DOWN (TEMPERATURE)
THE CAR IS HARDER
TO START - NEVER STARTS
ON 1ST CRANK WHEN
IT'S COOL OUTSIDE - IS
THIS NORMAL? THANKS

October 5, 2001

Via Facsimile

Jerry Mitre
Service Consultant
Gillespie Pontiac Greater Chicago Auto Sales, Inc.
6603 South Western Avenue
Chicago, Illinois 60636-2412

SECOND NOTICE

*Re: 2001 Pontiac Grand Prix GTP
Purchased at Gillespie Pontiac 7/30/01 (Demo Vehicle)
VIN 1G2WR12161F*

Dear Jerry:

Thank you for servicing the above vehicle on September 24th, and for arranging the loaner vehicle for that day. I appreciate your promptness in rescheduling the original Saturday appointment for Monday 9/24, and for having the above vehicle returned the same day. However, the same problems persist.

This letter is written to follow-up on the same problems that I wrote to you about on September 24, 2001. Specifically, during the rains of October 3rd and 4th, I observed water continuing to leak in through the passenger door, and on October 2nd the same engine oil leak was observed.

Therefore, as requested by Pontiac/GMC in the Warranty & Owner Assistance Manual (pgs. 27-28) addressing Warranty Enforcement Laws, I am again writing to you and to Pontiac/GMC to confirm that the same problems continue to plague this "new" vehicle. Please advise if this vehicle was in a major accident while used by Gillespie Pontiac as a "demo" for over 6,000 miles. I have not yet received any response. The vehicle was purchased in reliance upon the vehicle never having been in an accident.

A. ENGINE OIL LEAK

When I was at Gillespie Pontiac for my scheduled appointment of Saturday September 22, 2001, I pointed out the engine oil leak to you. The leak is located around an intake manifold bolt on the top of the engine in plain view (with the decorative plastic engine cover removed), on the passenger side, front of the engine. You confirmed the presence of oil, and agreed that the engine should not be leaking oil. I recall that you also commented that the bolt "was very low" and would require considerable time to repair since the entire manifold and everything above it would have to be removed to get to the gasket.

The response that was typed onto the invoice simply denied the presence of oil and commented on excess RTV that was squeezed out from the manifold gasket area. After picking up the vehicle, I noted that the oil stain was apparently cleaned, but the excess RTV was still present. A few days ago I again looked at the engine and the oil leak returned. Please advise of the next step(s) to be taken to remedy this problem, which I would appreciate being corrected the right way, the first time, rather than with some quick-and-cheap-fix, as may have been attempted on September 24th.

B. INTERIOR WATER LEAK AT PASSENGER DOOR

On September 24, 2001, you told me that Gillespie's contracted trim shop had confirmed the passenger door mis-alignment, and that they apparently re-adjusted the door alignment. They obviously did not water-test the door (or for that matter remove the water that was puddled in the passenger side

floor when I brought the car in). During the rains of October 3rd and 4th, the same passenger-side door leak was observed, with water leaking in/through the door, over the two stereo speakers in the door, and onto the carpet on the passenger side of the vehicle.

Therefore, during my short ownership of this vehicle, the vehicle has leaked every time it rained. This indicates a chronic problem existed for some time, including the many months and over 6,000 miles that Gillespie used and maintained this vehicle. Again, I wish to reiterate my concern that this vehicle may have been in a major accident and negligently repaired prior to my purchasing the vehicle, and that there may be other problems, such as in trunk/engine compartment leaks, or which may not readily be identified, but may nonetheless lead to premature component failures.

C. SECONDARY DAMAGE/PREMATURE FAILURES

I am still concerned about the following secondary damage and/or premature failures:

- (a) secondary/premature engine damage due to the manifold gasket oil leak;
- (b) damage to the two stereo speakers in the door, which were both observed to have water leaking directly over them;
- (c) electrical problems/corrosion/shorts due to water leakage;
- (d) mold/bacteria growth in the interior of the car (carpet/door), in light of which I request complete replacement of the interior floor carpet;
- (e) premature rusting/corrosion of the floor panels, doors and interior components due to water leakage that may have existed for over 6,000 miles prior to vehicle purchase;
- (f) other problems, misalignments or premature failures that were not identified prior to my taking possession of the vehicle.

Although the above problems are covered under the warranty, I have already spent time bringing the vehicle to your dealership on September 22, 2001, then dropping off the vehicle in the morning on September 24, 2001, and picking it up in the evening on September 24th. It seems that I will have to waste additional time for the same problems that Pontiac/GMC or Gillespie Pontiac had more than ample opportunity to discover and correct.

Specifically, these very obvious problems should have been identified and corrected prior to my purchase of the vehicle: (a) by Pontiac/GMC during quality control inspections at the factory or (b) during Gillespie's inspection and "new vehicle preparation" upon delivery from the factory, or (c) by Gillespie Pontiac while it was being maintained and used by your dealership for over 6,000 (initial) miles, or (d) during the thorough inspection and clean-up that John Meyer told me was performed prior to my purchase of the vehicle.

Please call me at _____ and let me know what can be done to correct these problems, and/or if Gillespie is unable (or unwilling) to address the problems. I appreciate the responsiveness and attention that you demonstrated during my last visits to Gillespie's service department. Thank you.

Sincerely,



cc: Pontiac-GMC Customer Assistance Center
PO Box 33172, Detroit, Michigan 48232-5172

CHICAGO, ILLINOIS

Pontiac-GMC Customer Assistance Center
PO Box 33172
Detroit, Michigan 48232-5172



CHICAGO, ILLINOIS

Jerry Mitre
Service Consultant
Gillespie Pontiac Greater Chicago Auto Sales, Inc.
6603 South Western Avenue
Chicago, Illinois 60636-2412



CHICAGO, ILLINOIS

November 20, 2001

Hand Delivered

Jerry Mitre
Greater Chicago Auto Sales, Inc.
d/b/a Gillespie Pontiac
6603 South Western Avenue
Chicago, Illinois 60636

RE: 2001 Pontiac Grand Prix Purchased from Gillespie Pontiac
VIN: 1G2WR12161F

Dear Jerry:

This letter is intended to highlight the major concerns which I have at this time regarding the above vehicle, and the reason for this most recent visit to Gillespie's Service Department.

1. Observation of dye which was placed into the oil during the last visit to check for an oil leak at or near an intake manifold bolt.
2. Checking both doors for wind blowing into vehicle through doors (when vehicle is moving) when window is cracked open slightly. The door handles are blowing out as much air as the vents, except that the air through the door handles is at the outside air temperature.
3. Checking the trip odometer (above the vehicle odometer), which periodically works and recently stopped working.
4. Performing a front-wheel alignment at the Gillespie coupon price. I understand that the cost for the wheel alignment is not covered under warranty. I noticed the vehicle pulling to the left on straight highway sections. Please check when aligning, and make sure the steering wheel is set correctly when the alignment is finished (i.e. straight with tires).
5. I have also recently heard a buzzing noise from the engine (sounds like near the power steering pump), which gets louder with acceleration. Please advise if this is any cause for concern.

Finally, the sticker in the trunk of the car specifies "H" rated tires for this vehicle. The tires which Gillespie sold on this vehicle are Goodyear Eagle LS tires 225/60R16, which according to the Goodyear website, are not "H" speed rated. Please let me know if these substituted tires will adversely affect the suspension, handling and/or safety of this vehicle. Should this car have been equipped with the "H" rated tires to start with in order to meet Pontiac/GMC specifications? Thanks.

Sincerely,

cc: Pontiac/GMC Warranty Enforcement (via First Class Mail) ✓

[REDACTED]
CHICAGO, ILLINOIS [REDACTED]
[REDACTED]

November 21, 2001

Via Facsimile

Jerry Mitre
Greater Chicago Auto Sales, Inc.
d/b/a Gillespie Pontiac
6603 South Western Avenue
Chicago, Illinois 60636

RE: 2001 Pontiac Grand Prix Purchased from Gillespie Pontiac
VIN: 1G2WR12161F [REDACTED]

Dear Jerry:

I apologize for not being able to bring my car in on Tuesday morning. Thank you for being so accommodating and rescheduling the appointment for Monday November 26th.

Also, thank you for arranging the loaner vehicle during my last visit to Gillespie, and for replacing the various seals that were damaged and/or misaligned in the passenger-side door and mirror assembly, which were determined to be the reason for the water leakage through the passenger side door. The repairs were performed quickly during one business day, as promised, and seem to have resolved the water leaks through both the front and rear portions of the passenger door.

This letter is also intended to highlight some of the more important concerns regarding the above vehicle (some of which were previously raised), and the reason for the November 26th visit to Gillespie's Service Department.

1. To check if the dye which was placed into the oil during the last visit is leaking at or near one of the (lower) intake manifold/plenum bolts.
2. Checking both doors for wind blowing into the car through the door handles (and into the passenger compartment) when the vehicle is moving and a window is slightly open. There is as much air blowing through the door handles as from the vents, except that the air through the door handles is at the outside air temperature, which is quickly dropping. A small amount of air enters through the door handles even when all windows are closed.
3. Please check the trip odometer (above the vehicle's total mileage odometer) in the dash, which periodically works and other times stops working (e.g. stays at 0000 even when driving).
4. Please also perform a wheel alignment at the Gillespie coupon price of \$59.99 (which I understand is not warranty work). I noticed the vehicle pulling to the left on flat highway sections – please check when aligning. Also, please make sure that the steering wheel is properly aligned and set correctly when finished (i.e. straight with the tires).
5. I have also recently heard a buzzing noise from the engine (sounds like near the power steering pump?), which gets louder with acceleration. Please advise if this is any cause for concern.

Finally, the sticker in the trunk of the car specifies "H" rated tires for this vehicle. The tires which Gillespie sold on this vehicle are Goodyear Eagle LS tires 225/60R16, which according to the Goodyear website, are not "H" speed rated. If I am mistaken, then please identify the source which confirms that the Eagle LS tires are in fact "H" rated. Otherwise, let me know if these substituted tires will adversely affect the suspension, handling and/or safety of this vehicle. Should this car have been equipped with the "H" rated tires to start with in order to meet Pontiac/GMC specifications and warranty requirements? In the future, do I need to purchase/upgrade to "H" rated replacement tires?

I also wish to confirm that Gillespie's Rick Lanam represented to me in a telephone call about one month ago that the above vehicle was not in an accident, but did have some body work to one of the bumper areas prior to my purchasing of the vehicle. This information was not provided by my salesperson, John Meyers, when I asked him what, if any, service work was performed on the vehicle while it was being used by Gillespie as a demo vehicle. John Meyers told me that all work was provided by Gillespie – which he stated consisted of a single oil change at approximately 6,000 miles, just prior to my purchase of the vehicle.

Overall, I appreciate the patience, attention and persistence that you personally have demonstrated during my visits to Gillespie's Service Department. Thank you.

Sincerely,

A large black rectangular redaction box covering the signature area.

cc: Pontiac/GMC Warranty Enforcement (via First Class Mail)

[REDACTED]
Chicago, Illinois [REDACTED]

December 7, 2001

Pontiac-GMC Customer Assistance
Warranty Enforcement
PO Box 33172
Detroit, Michigan 48232-5172

Re: **Warranty Enforcement / File**
VIN 1G2WR12161F [REDACTED]

To Whom It May Concern:

This letter is written to clarify concerns raised in my November 21, 2001, letter to Jerry Mitre at Gillespie Pontiac in Chicago, Illinois (copy attached). Jerry Mitre is an excellent service associate, and was very patient, attentive and professional when addressing my concerns. Also, I appreciate that the dealership honored GM's \$30/day auto rental allowance and provided a voucher for a rental car when the vehicle was being serviced this last time. Gillespie had provided one of their vehicles to me during the previous warranty-work visits to their service department.

The dealership replaced the Eagle LS tires with H-rated Goodyear tires, which should have been on this car from the start according to the sticker in the trunk of the vehicle (and which were undoubtedly factored into the original purchase price of the vehicle). The dealership told me that the reason that the car was pulling to the left (and continues pulling to the left) was because of the inferior tires that were on the car when I bought it. I was told that the new H-rated tires should resolve the pulling issue – they have not, and I will have to bring the car in yet again for the pulling to the left issue as soon as I can schedule the time away from work.

Gillespie's service department was not able to provide solutions for the other concerns. Accordingly, their work order/ticket should be corrected to read "no solution" rather than no problem since wind blowing through the door handles and oil on the engine manifold are still present. Not only did Jerry Mitre observe the oil, but an independent mechanic also confirmed oil on the manifold. The problem is still there, but as I understand it, is simply not a major or significant enough of an oil leak to justify service work at this time.

The wind blowing through the doors is a major concern of mine, and although Gillespie Pontiac confirmed that the same problem was present on another vehicle, and there were no TSBs for this problem, the problem persists. As such, this is a Pontiac issue (rather than a dealership issue), and I raise the issue for your engineering department. Is there an error or omission in the vehicle's door design, such that not only is wind blowing through the door (as strong as through the vent at level 2 or 3), but is water/salt also entering the door and leading to premature failures/safety concerns? Please advise if Pontiac will be offering a solution for the door-handle wind problem. It is very annoying, particularly since it blows right on my left hand when I hold the steering wheel.

Thank you.

Very truly yours,
[REDACTED]

Enclosure

[REDACTED]
CHICAGO, ILLINOIS [REDACTED]
[REDACTED]

November 21, 2001

Via Facsimile

Jerry Mitre
Greater Chicago Auto Sales, Inc.
d/b/a Gillespie Pontiac
6603 South Western Avenue
Chicago, Illinois 60636

RE: 2001 Pontiac Grand Prix Purchased from Gillespie Pontiac
VIN: 1G2WR12161F [REDACTED]

Dear Jerry:

I apologize for not being able to bring my car in on Tuesday morning. Thank you for being so accommodating and rescheduling the appointment for Monday November 26th.

Also, thank you for arranging the loaner vehicle during my last visit to Gillespie, and for replacing the various seals that were damaged and/or misaligned in the passenger-side door and mirror assembly, which were determined to be the reason for the water leakage through the passenger side door. The repairs were performed quickly during one business day, as promised, and seem to have resolved the water leaks through both the front and rear portions of the passenger door.

This letter is also intended to highlight some of the more important concerns regarding the above vehicle (some of which were previously raised), and the reason for the November 26th visit to Gillespie's Service Department.

1. To check if the dye which was placed into the oil during the last visit is leaking at or near one of the (lower) intake manifold/plenum bolts.
2. Checking both doors for wind blowing into the car through the door handles (and into the passenger compartment) when the vehicle is moving and a window is slightly open. There is as much air blowing through the door handles as from the vents, except that the air through the door handles is at the outside air temperature, which is quickly dropping. A small amount of air enters through the door handles even when all windows are closed.
3. Please check the trip odometer (above the vehicle's total mileage odometer) in the dash, which periodically works and other times stops working (e.g. stays at 0000 even when driving).
4. Please also perform a wheel alignment at the Gillespie coupon price of \$59.99 (which I understand is not warranty work). I noticed the vehicle pulling to the left on flat highway sections – please check when aligning. Also, please make sure that the steering wheel is properly aligned and set correctly when finished (i.e. straight with the tires).
5. I have also recently heard a buzzing noise from the engine (sounds like near the power steering pump?), which gets louder with acceleration. Please advise if this is any cause for concern.

Finally, the sticker in the trunk of the car specifies "H" rated tires for this vehicle. The tires which Gillespie sold on this vehicle are Goodyear Eagle LS tires 225/60R16, which according to the Goodyear website, are not "H" speed rated. If I am mistaken, then please identify the source which confirms that the Eagle LS tires are in fact "H" rated. Otherwise, let me know if these substituted tires will adversely affect the suspension, handling and/or safety of this vehicle. Should this car have been equipped with the "H" rated tires to start with in order to meet Pontiac/GMC specifications and warranty requirements? In the future, do I need to purchase/upgrade to "H" rated replacement tires?

I also wish to confirm that Gillespie's Rick Lanam represented to me in a telephone call about one month ago that the above vehicle was not in an accident, but did have some body work to one of the bumper areas prior to my purchasing of the vehicle. This information was not provided by my salesperson, John Meyers, when I asked him what, if any, service work was performed on the vehicle while it was being used by Gillespie as a demo vehicle. John Meyers told me that all work was provided by Gillespie – which he stated consisted of a single oil change at approximately 6,000 miles, just prior to my purchase of the vehicle.

Overall, I appreciate the patience, attention and persistence that you personally have demonstrated during my visits to Gillespie's Service Department. Thank you.

Sincerely,



cc: Pontiac/GMC Warranty Enforcement (via First Class Mail)

[REDACTED]
[REDACTED], Chicago, Illinois [REDACTED]
[REDACTED]

January 4, 2002

Via Facsimile to (773) 434-5906

Jerry Mitre
Gillespie Pontiac
6603 S. Western Avenue
Chicago, Illinois 60636

Re: **2001 Pontiac GTP/VIN 1G2WR12161F [REDACTED]**
Warranty Enforcement File [REDACTED]

Dear Jerry:

This letter is written to confirm recent service work performed on the above car, and to let you know that the Service Engine Soon ("SES") light came back on within 24 hours of getting the car back from Gillespie. I noticed the SES light come on initially on December 25th, and started off the new year with the car at Gillespie's service department on January 2, 2002. In addition, that morning, the CD player refused to accept CDs, and generated a code E23 on the display. I appreciate your going out of your way to arrange for the \$30.00 rental car voucher for the day, while the repair work was under way.

In the afternoon on January 2nd, you confirmed that the CD player was removed and sent away for service, which would take about one week, during which time I would be without a radio/CD player. Also, I was told that a connector at the fuel pump had to be reconnected, and the PCM was reflashed, as a result of the SES light. When I picked up the car, the SES light was not illuminated. However, within 24 hours of picking up the car, during the 3rd drive cycle (start engine - drive - turn off engine) the SES came back on. I was driving in moderate traffic on Addison Street in Chicago (around 30-35 mph) when the light came back on.

Although I understand that Gillespie did not build the vehicle, I was optimistic that it would be repaired correctly the first time (and since I am a "preferred" customer, by virtue of buying the car from Gillespie). Although your service department is nice enough, believe me, I do not enjoy wasting time (and gas) driving to and from Gillespie's shop and/or Enterprise Rental, taking care of this "new" car, particularly this soon. (Nor do I enjoy driving the little economy cars that don't compare to the GTP, but are the only cars fit within the \$30/day voucher.) This reminds me of the water leak problem at the passenger-side door, when I had to waste time bringing the car back three times before it was finally fixed. I had hoped that in buying a demo vehicle, it would have been well maintained and thoroughly checked over, and all the "bugs" taken care of before I bought it. I realize now that it wasn't a good idea at all to buy a demo vehicle.

Anyway, I tried calling this morning and again this afternoon to discuss a solution with you, but was transferred both times to your voice mail. I left messages with my phone number, but was not able to speak with you today. I had also hoped to check with you to see if it was OK/safe to continue driving the car over the weekend and Monday, since I am unable to bring the vehicle back to Gillespie until Tuesday, and have no alternative transportation available. As always, you can call and/or leave a message for me at work _____ or on my cell phone _____.
Thanks for your continued patience and attention to the recurring problems with this "new" car.

Very truly yours,

[REDACTED]

cc: Pontiac-GMC Customer Assistance / Warranty Enforcement (via First Class Mail)
PO Box 33172, Detroit, Michigan 48232-5172

October 23, 2002

Hand Delivered

Jerry Mitre
Service Consultant
Gillespie Pontiac Greater Chicago Auto Sales, Inc.
6603 South Western Avenue
Chicago, Illinois 60636-2412

Re: 2001 Pontiac Grand Prix GTP
Purchased at Gillespie Pontiac 7/30/01 (Demo Vehicle)
VIN 1G2WR12161F

Dear Jerry:

Thanks for agreeing to take a look at the car today. Since we last spoke, the car has been operating without any major problems, and required only oil changes (performed every 3,000 miles, with Mobil 1 synthetic oil), front brake/rotor replacement (early) and air filter maintenance. Although I still really enjoy driving the car, there are some continuing and some new problems, listed below.

- (1) Water leak from sunroof, passenger side front. Occurred on Thursday 10/17, with a water puddle collecting on the passenger seat and wet area up top around the sunroof.
- (2) CD player occasionally has error codes E20 and/or E23 and ejects CD, or when it does play, it skips with virtually every seam and bump in the road. This problem started within weeks after getting the CD player back last time, and may indicate the need to replace the CD unit.
- (3) Car still drifts to the left. This was previously attributed to incorrect tires, which were replaced by Gillespie last year. However, the problem continues.
- (4) Abnormal knock in the front end, driver side when car goes over certain bumps in the road (possible bad wheel bearing or front end component). May be related to (3) above?
- (5) Very loud groaning/buzzing noise after vehicle makes a turn (both right and left), which may indicate either impending power steering system failure, or rack-and-pinion failure. I check the power steering fluid periodically, and it has never been low, though at low speeds (i.e. parking the car), steering seems more difficult (i.e. less power assist).
- (6) Driver's side plastic panel on outside of door is coming off from the top, and looks like a push-in pin-connector is missing the backing/locking piece.
- (7) Rear seat center arm rest/cup holder keeps falling down, and doesn't stay up.

Sincerely,

cc: Pontiac-GMC Customer Assistance Center (via mail)
PO Box 33172, Detroit, Michigan 48232-5172



773 434-8200
Fax 773 434-5906



6603-33 So. Western Ave.
Chicago, Illinois 60636

DISCLAIMER OF WARRANTIES - Any warranties on the products sold hereby are those made by the manufacturer. The Selling Dealer hereby expressly disclaims all warranties, either express or implied, including any implied warranty of merchantability or fitness for a particular purpose, and the Selling Dealer neither assumes nor authorizes any other person to assume for it any liability in connection with the sale of this part(s) and/or service. Buyer shall not be entitled to recover from the Selling Dealer any consequential damages, damages to property, damages for loss of use, loss of time, loss of profit or income, or any other incidental damages.

CUSTOMER NO	ADVISOR JEREMIAH MITRE	FAC NO 6907	INVOICE DATE 09/24/01	INVOICE NO PNC529060
LABOR RATE 70.00	LICENSE NO.	MILEAGE 7,462	COLOR NAVY BLUE M	STOCK NO. 5360
YEAR / MAKE / MODEL 01/PONTIAC/GRAND PRIX/2DR CPE GTP	VEHICLE I.D. NO. 1 G 2 W R 1 2 1 6 1 F		DELIVERY DATE 07/30/01	DELIVERY MILES 6,011
RESIDENCE PHONE	BUSINESS PHONE	COMMENTS	SELLING DEALER NO.	PRODUCTION DATE
			R.O. DATE 09/24/01	

J# 1 61PNZ	EXTERIOR TRIM	UNITS: 0.30	TECH(S): 999	WARRANTY
CUSTOMER STATES THAT WATER IS LEAKING THROUGH PASSENGER SIDE FRONT DOOR. SUBLET OUT FOR REPAIRS, ADJUSTED RIGHT SIDE FRONT DOOR WEATHERSTRIP, AND ADJUSTED RIGHT SIDE DOOR LATCH.				
JOB # 1 TOTAL LABOR & PARTS				0.00
J# 2 11PNZ	ENGINE MINOR	UNITS:	TECH(S): 999	0.00
CHECK FOR ENGINE OIL LEAK. CHECKED FOR POSSIBLE OIL, NONE FOUND ADVISED CUSTOMER THAT WHAT HE SAW WAS RTV SEALANT. (NORMAL)				
JOB # 2 TOTAL LABOR & PARTS				0.00
J# 3 70PNZ03	RENTAL	UNITS:	TECH(S): 999	0.00
RENTAL RENTAL				
JOB # 3 TOTAL LABOR & PARTS				0.00
SUBLET	PO#	VEND INV#	INV. DATE	DESCRIPTION
JOB # 1	10809		09/24/01	LEAKING
TOTAL - SUBLET				0.00

IMPORTANT
You will receive a survey from Pontiac shortly. Your Complete Satisfaction is our goal. If for any reason you cannot give us a "Completely Satisfied" please contact Service Manager before mailing survey.
Gillespie Pontiac
(773) 434-8200

COMMENTS: CALL

TOTALS:

TOTAL LABOR....	0.00
TOTAL PARTS....	0.00
TOTAL SUBLET....	0.00
TOTAL G.O.G....	0.00
TOTAL MISC CHG.	0.00
TOTAL MISC DISC	0.00
TOTAL TAX.....	0.00
TOTAL INVOICE \$	0.00

THANK YOU FOR YOUR BUSINESS!!

CUSTOMER SIGNATURE

PAID

Copyright © 1998 The Reynolds and Reynolds Company ERMNTS116 C000604 (001)



GM SERVICE CENTER

6603-33 So. Western Ave.
 Chicago, Illinois 60636
 773 434-8200
 Fax 773 470-2790



www.gillespieautogroup.com

DISCLAIMER OF WARRANTIES - Any warranties on the products sold hereby are those made by the manufacturer. The Selling Dealer hereby expressly disclaims all warranties, either express or implied, including any implied warranty of merchantability or fitness for a particular purpose, and the Selling Dealer neither assumes nor authorizes any other person to assume for it any liability in connection with the sale of this part(s) and/or service. Manufacturer's warranty 12 months/12,000 miles parts and labor. Buyer shall not be entitled to recover from the Selling Dealer any consequential damages, damages to property, damages for loss of use, loss of time, loss of profit or income, or any other incidental damages.

CUSTOMER NO. [REDACTED]	ADVISOR JEREMIAH MITRE	6907	TAG NO. [REDACTED]	INVOICE DATE 09/24/01	INVOICE NO. PNC529060
[REDACTED]	LABOR RATE 105.00	LICENSE NO.	MILEAGE 7,462	COLOR NAVY BLUE M	STOCK NO.
CHICAGO, IL	YEAR / MAKE / MODEL 01/PONTIAC/GRAND PRIX/2 DOOR COUPE			DELIVERY DATE 07/30/01	DELIVERY MILES 6,011
	VEHICLE I.D. NO. 1 G 2 W R 1 2 1 6 1 F			SELLING DEALER NO.	PRODUCTION DATE
	F.T.E. NO.		P.O. NO.	R.O. DATE 09/24/01	
	COMMENTS				

LABOR & PARTS

J# 1 61PNZ EXTERIOR TRIM UNITS: 0.30 TECH(S): 999 WARRANTY
 CUSTOMER STATES THAT WATER IS LEAKING THROUGH PASSENGER SIDE FRONT DOOR.
 SUBLET OUT FOR REPAIRS. ADJUSTED RIGHT SIDE FRONT DOOR WEATHERSTRIP. AND ADJUSTED RIGHT SIDE DOOR LATCH.
 JOB # 1 TOTAL LABOR & PARTS 0.00

J# 2 71PNZ ENGINE MINOR UNITS: TECH(S): 999 0.00
 CHECK FOR ENGINE OIL LEAK.
 CHECKED FOR POSSIBLE OIL. NONE FOUND ADVISED CUSTOMER THAT WHAT HE SAW WAS RTV SEALANT. (NORMAL)
 JOB # 2 TOTAL LABOR & PARTS 0.00

J# 3 70PNZ03 RENTAL UNITS: TECH(S): 999 0.00
 RENTAL
 RENTAL
 JOB # 3 TOTAL LABOR & PARTS 0.00

SUBLET PO# 10809 VEND INV# 09/24/01 INV. DATE 10809 DESCRIPTION LEAKING WARRANTY
 JOB # 1 10809 09/24/01 LEAKING
 TOTAL - SUBLET 0.00

COMMENTS
 CALL

TOTALS

 * NEXT RECOMMENDED SERVICE: *
 * 12/04/2006 / 13462 MI 01PNZZRT TIRE ROTATE *

 * TOTAL LABOR 0.00 *
 * TOTAL PARTS 0.00 *
 * TOTAL SUBLET 0.00 *
 * TOTAL G.O.G. 0.00 *
 * TOTAL MISC CHG. 0.00 *
 * TOTAL MISC DISC 0.00 *
 * TOTAL TAX 0.00 *

TOTAL INVOICE \$ 0.00

THANK YOU FOR YOUR BUSINESS!!

CUSTOMER SIGNATURE _____
 ***** DUPLICATE INVOICE *****

CHEVROLET

PONTIAC

GMC

BUICK

Cadillac

Goodwrench



6603-33 So. Western Ave.
Chicago, Illinois 60636

DISCLAIMER OF WARRANTIES - Any warranties on the products sold hereby are those made by the manufacturer. The Selling Dealer hereby expressly disclaims all warranties, either express or implied, including any implied warranty of merchantability or fitness for a particular purpose, and the Selling Dealer neither assumes nor authorizes any other person to assume for it any liability in connection with the sale of this part(s) and/or service. Buyer shall not be entitled to recover from the Selling Dealer any consequential damages, damages to property, damages for loss of use, loss of time, loss of profit or income, or any other incidental damages.

CUSTOMER NO.	ADVISOR JEREMIAH MITRE	TAG NO. 6907	INVOICE DATE 10/10/01	INVOICE NO. PNCS29836
CHICAGO, IL	LABOR RATE 80.00	LICENSE NO.	MILEAGE 7,737	COLOR NAVY BLUE M
	YEAR / MAKE / MODEL 01/PONTIAC/GRAND PRIX/2DR CPE GTP		DELIVERY DATE 07/30/01	STOCK NO. 5360
	VEHICLE I.D. NO. 1 G 2 W R 1 2 1 6 1 F		SELLING DEALER NO.	DELIVERY MILES 6,011
	F. T. E. NO.	P. O. NO.	R. O. DATE 10/09/01	PRODUCTION DATE
RESIDENCE PHONE	BUSINESS PHONE	COMMENTS		

TOTALS

*****	TOTAL LABOR.....	0.00
* [] CASH [] CHECK CK NO. []	TOTAL PARTS.....	0.00
* [] VISA [] MASTERCARD [] DISCOVER	TOTAL SUBLET...	0.00
* [] AMER XPRESS [] OTHER [] CHARGE	TOTAL G.O.G....	0.00
*****	TOTAL MISC CHG.	0.00
	TOTAL MISC DISC	0.00
	TOTAL TAX.....	0.00
	TOTAL INVOICE \$	0.0

THANK YOU FOR YOUR BUSINESS!!

IMPORTANT
You will receive a survey from Pontiac shortly. Your Complete Satisfaction is our goal. If for any reason you cannot give us a "Completely Satisfied" please contact Service Manager before mailing survey.
Gillespie Pontiac
(773) 434-8200

CUSTOMER SIGNATURE

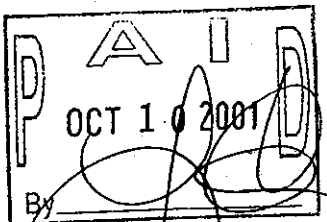



773 434-8200
Fax 773 434-5906



6603-33 So. Western Ave.
Chicago, Illinois 60636

DISCLAIMER OF WARRANTIES - Any warranties on the products sold hereby are those made by the manufacturer. The Selling Dealer hereby expressly disclaims all warranties, either express or implied, including any implied warranty of merchantability or fitness for a particular purpose, and the Selling Dealer neither assumes nor authorizes any other person to assume for it any liability in connection with the sale of this part(s) and/or service. Buyer shall not be entitled to recover from the Selling Dealer any consequential damages, damages to property, damages for loss of use, loss of time, loss of profit or income, or any other incidental damages.

CUSTOMER NO. [REDACTED]	ADVISOR JEREMIAH MITRE	TAG NO. 6907	INVOICE DATE 10/10/01	INVOICE NO. PNCS29836
[REDACTED]	LABOR RATE 80.00	LICENSE NO.	MILEAGE 7,737	COLOR NAVY BLUE M
CHICAGO, IL	YEAR / MAKE / MODEL 01/PONTIAC/GRAND PRIX/2DR CPE GTP	DELIVERY DATE 07/30/01	STOCK NO. 5360	DELIVERY MILES 6,011
	VEHICLE ID NO. 1 G 2 W R 1 2 1 6 1 F	SELLING DEALER NO.	PRODUCTION DATE	
RESIDENCE PHONE [REDACTED]	BUSINESS PHONE [REDACTED]	F. T. E. NO.	P. O. NO.	R. O. DATE 10/09/01
COMMENTS				

LABOR & PARTS
J# 1 11PNZ04 FLUID LEAK-ENGINE UNITS: TECH(S):668 INTERNAL
 ADD DYE TO ENGINE AND CHECK AND ADVISE ON ENGINE OIL LEAK AND COOLANT LEAK.
 NO LEAK PRESENT AT THIS TIME DEALER ADDED OIL DYE AND COOLANT DYE
 CUSTOMER TO RETURN ON NEXT SERVICE DEALER WILL DYE TEST
 NO REPAIR PERFORMED

PARTS	QTY	FP-NUMBER	DESCRIPTION	UNIT PRICE	
JOB # 1	1	12345797	DYE-FLUOR 8.800		INTERNAL
JOB # 1	1	12345795	DYE-FLUOR 8.800		INTERNAL
				JOB # 1 TOTAL PARTS	0.00
				JOB # 1 TOTAL LABOR & PARTS	0.00

J# 2 61PNZ EXTERIOR TRIM UNITS: 0.60 TECH(S):668 WARRANTY
 CUSTOMER STATES THAT WATER IS LEAKING THROUGH PASSENGER SIDE FRONT DOOR. (SOUTHWEST)
 R/FRONT DOOR WEATHERSTRIP DEFORMED CAUSING LEAK FROM R/FRONT DOOR
 REPLACE R/FRONT DOOR WEATHERSTRIP RECHECK AFTER REPAIR
 NO LEAK NOW PRESENT.

PARTS	QTY	FP-NUMBER	DESCRIPTION	UNIT PRICE	
JOB # 2	1	10409207	W/STR-S/D 10.694		WARRANTY
JOB # 2	1	1052915	SEALANT 8.800		WARRANTY
				JOB # 2 TOTAL PARTS	0.00
				JOB # 2 TOTAL LABOR & PARTS	0.00

J# 3 70PNZ03 RENTAL UNITS: TECH(S):668 WARRANTY
 RENTAL FOR CUSTOMER WHILE VEHICAL IS SHOP WHILE BEING INSPECTED.
 1 DAY RENTAL CUSTOMER SATISFACTION

PARTS	QTY	FP-NUMBER	DESCRIPTION	UNIT PRICE	
				JOB # 3 TOTAL PARTS	0.00
				JOB # 3 TOTAL LABOR & PARTS	0.00

SUBLET	PO#	VEND INV#	INV.DATE	DESCRIPTION	
JOB # 3	11123		10/10/01	RENTAL	WARRANTY
				TOTAL - SUBLET	0.00

COMMENTS
CALL

Copyright © 1998 The Reynolds and Reynolds Company ERM1514E CG23504 (1/01)



DISCLAIMER OF WARRANTIES - Any warranties on the products sold hereby are those made by the manufacturer. The Selling Dealer hereby expressly disclaims all warranties, either express or implied, including any implied warranty of merchantability or fitness for a particular purpose, and the Selling Dealer neither assumes nor authorizes any other person to assume for it any liability in connection with the sale of this part(s) and/or service. Manufacturer's warranty 12 months/12,000 miles parts and labor. Buyer shall not be entitled to recover from the Selling Dealer any consequential damages, damages to property, damages for loss of use, loss of time, loss of profit or income, or any other incidental damages.

CUSTOMER NO.	ADVISOR JEREMIAH MITRE	6907	TAG NO.	INVOICE DATE 10/10/01	INVOICE NO. PNC529836
CHICAGO, IL	LABOR RATE 105.00	LICENSE NO.	MILEAGE 7,737	COLOR NAVY BLUE M	STOCK NO.
	YEAR / MAKE / MODEL 01/PONTIAC/GRAND PRIX/2 DOOR COUPE			DELIVERY DATE 07/30/01	DELIVERY MILES 6,011
	VEHICLE I.D. NO. 1 G 2 W R 1 2 1 6 1 F			SELLING DEALER NO.	PRODUCTION DATE
	F.T.E. NO.	P.O. NO.	P.O. DATE 10/09/01		

REFERENCE PHONE: [REDACTED] COMMENTS:

LABOR & PARTS
1 11PNZ04 FLUID LEAK ENGINE UNITS: TECH(S): 668 INTERNAL
 ADD DYE TO ENGINE AND CHECK AND ADVISE ON ENGINE OIL LEAK AND COOLANT LEAK.
 NO LEAK PRESENT AT THIS TIME DEALER ADDED OIL DYE AND COOLANT DYE
 CUSTOMER TO RETURN ON NEXT SERVICE DEALER WILL DYE TEST
 NO REPAIR PERFORMED

PARTS	QTY	FP-NUMBER	DESCRIPTION	UNIT PRICE	
JOB # 1	1	12345797	DYE-FLUOR 8.800		INTERNAL
JOB # 1	1	12345795	DYE-FLUOR 8.800		INTERNAL
				JOB # 1 TOTAL PARTS	0.00
				JOB # 1 TOTAL LABOR & PARTS	0.00

2 61PNZ EXTERIOR TRIM UNITS: 0.80 TECH(S): 668 WARRANTY
 CUSTOMER STATES THAT WATER IS LEAKING THROUGH PASSENGER SIDE FRONT DOOR. (SOUTHWEST)
 R/FRONT DOOR WEATHERSTRIP DEFORMED CAUSING LEAK FROM R/FRONT DOOR
 REPLACE R/FRONT DOOR WEATHERSTRIP RECHECK AFTER REPAIR
 NO LEAK NOW PRESENT.

PARTS	QTY	FP-NUMBER	DESCRIPTION	UNIT PRICE	
JOB # 2	1	10409207	W/STR-S/D 10.694		WARRANTY
JOB # 2	1	1052915	SEALANT 8.800		WARRANTY
				JOB # 2 TOTAL PARTS	0.00
				JOB # 2 TOTAL LABOR & PARTS	0.00

3 70BNZ03 RENTAL UNITS: TECH(S): 668 WARRANTY
 RENTAL FOR CUSTOMER WHILE VEHICLE IS SHOP WHILE BEING INSPECTED.
 1 DAY RENTAL CUSTOMER SATISFACTION

PARTS	QTY	FP-NUMBER	DESCRIPTION	UNIT PRICE	
				JOB # 3 TOTAL PARTS	0.00
				JOB # 3 TOTAL LABOR & PARTS	0.00

SUBLET	PO#	VEND INV#	INV. DATE	DESCRIPTION	
JOB # 3	11123		10/10/01	RENTAL	WARRANTY
				TOTAL - SUBLET	0.00

COMMENTS: CALL



Cadillac



Goodwrench



DISCLAIMER OF WARRANTIES - Any warranties on the products sold hereby are those made by the manufacturer. The Selling Dealer hereby expressly disclaims all warranties, either express or implied, including any implied warranty of merchantability or fitness for a particular purpose, and the Selling Dealer neither assumes nor authorizes any other person to assume for it any liability in connection with the sale of this part(s) and/or service. Manufacturer's warranty 12 months/12,000 miles parts and labor. Buyer shall not be entitled to recover from the Selling Dealer any consequential damages, damages to property, damages to property, damages for loss of use, loss of time, loss of profit or income, or any other incidental damages.

CUSTOMER NO. [REDACTED]	ADVISOR JEREMIAH MITRE	6907	TAG NO. [REDACTED]	INVOICE DATE 10/10/01	INVOICE NO. PNCS29836
[REDACTED]	LABOR RATE 105.00	LICENSE NO.	MILEAGE 7,737	COLOR NAVY BLUE M	STOCK NO.
CHICAGO, IL	YEAR / MAKE / MODEL 01/PONTIAC/GRAND PRIX/2 DOOR COUPE			DELIVERY DATE 07/30/01	DELIVERY MILES 6,011
	VEHICLE I.D. NO. 1 G 2 W R 1 2 1 6 1 F			SELLING DEALER NO.	PRODUCTION DATE
	F.T.E. NO.	P.O. NO.	R.O. DATE 10/09/01		
COMMENTS					

TOTALS

 * NEXT RECOMMENDED SERVICE: *
 * 12/05/2006 / 13737 MI 01PNZZRT TIRE ROTATE *

*****	TOTAL LABOR....	0.00
*	TOTAL PARTS....	0.00
* [] CASH [] CHECK CK NO. [] *	TOTAL SUBLET...	0.00
*	TOTAL G.O.G....	0.00
* [] VISA [] MASTERCARD [] DISCOVER *	TOTAL MISC CHG.	0.00
*	TOTAL MISC DISC	0.00
* [] AMER XPRESS [] OTHER [] CHARGE *	TOTAL TAX.....	0.00
*****	TOTAL INVOICE \$	0.00

THANK YOU FOR YOUR BUSINESS!!



CHEVROLET



PONTIAC



GMC



BUICK

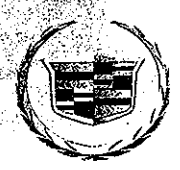

Cadillac



Goodwrench

CUSTOMER SIGNATURE _____

***** DUPLICATE INVOICE *****



773 434-8200
Fax 773 434-5906



6603-33 So. Western Ave.
Chicago, Illinois 60636

DISCLAIMER OF WARRANTIES - Any warranties on the products sold hereby are those made by the manufacturer. The Selling Dealer hereby expressly disclaims all warranties, either express or implied, including any implied warranty of merchantability or fitness for a particular purpose, and the Selling Dealer neither assumes nor authorizes any other person to assume for it any liability in connection with the sale of this part(s) and/or service. Buyer shall not be entitled to recover from the Selling Dealer any consequential damages, damages to property, damages for loss of use, loss of time, loss of profit or income, or any other incidental damages.

CUSTOMER NO.	ADVISOR JEREMIAH MITRE	TAG NO. 6907	INVOICE DATE 11/27/01	INVOICE NO. PNCS32262
CHICAGO, IL	LABOR RATE 80.00	LICENSE NO.	MILEAGE 8,985	COLOR NAVY BLUE M
	YEAR / MAKE / MODEL 01/PONTIAC/GRAND PRIX/2DR CPE GTP		DELIVERY DATE 07/30/01	STOCK NO. 5360
	VEHICLE I.D. NO. 1 G 2 W R 1 2 1 6 1 F		SELLING DEALER NO.	DELIVERY MILES 6,011
	F.T.E. NO.	P.O. NO.	R.O. DATE 11/26/01	PRODUCTION DATE
RESIDENCE PHONE	BUSINESS PHONE	COMMENTS		

TOTALS-----

*****	TOTAL LABOR....	0.00
*	TOTAL PARTS....	0.00
* [] CASH [] CHECK CK NO. []	TOTAL SUBLET...	0.00
*	TOTAL G.O.G....	0.00
* [] VISA [] MASTERCARD [] DISCOVER	TOTAL MISC CHG.	0.00
*	TOTAL MISC DISC	0.00
* [] AMER XPRESS [] OTHER [] CHARGE	TOTAL TAX.....	0.00
*		
*****	TOTAL INVOICE \$	0.00

THANK YOU FOR YOUR BUSINESS!!

CUSTOMER SIGNATURE _____
***** DUPLICATE INVOICE *****

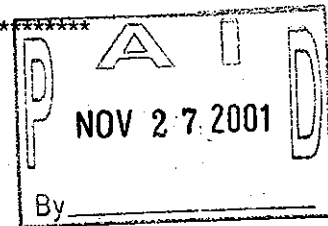

Copyright © 1998 The Reynolds and Reynolds Company EPRINTS114E CC238504 (1/01)



773 434-8200
Fax 773 434-5906



6603-33 So. Western Ave.
Chicago, Illinois 60636

DISCLAIMER OF WARRANTIES - Any warranties on the products sold hereby are those made by the manufacturer. The Selling Dealer hereby expressly disclaims all warranties, either express or implied, including any implied warranty of merchantability or fitness for a particular purpose, and the Selling Dealer neither assumes nor authorizes any other person to assume for it any liability in connection with the sale of this part(s) and/or service. Buyer shall not be entitled to recover from the Selling Dealer any consequential damages, damages to property, damages for loss of use, loss of time, loss of profit or income, or any other incidental damages.

CUSTOMER NO. [REDACTED]	ADVISOR JEREMIAH MITRE	6907	TAG NO. [REDACTED]	INVOICE DATE 11/27/01	INVOICE NO. PNCS32262
CHICAGO, IL [REDACTED]	LABOR RATE 80.00	LICENSE NO.	MILEAGE 8,985	COLOR NAVY BLUE M	STOCK NO. 5360
	YEAR / MAKE / MODEL 01/PONTIAC/GRAND PRIX/2DR CPE GTP			DELIVERY DATE 07/30/01	DELIVERY MILES 6,011
	VEHICLE I.D. NO. 1 G 2 W R 1 2 1 6 1 F			SELLING DEALER NO.	PRODUCTION DATE
	F. T. E. NO.		P. O. NO.		R. O. DATE 11/26/01
RESIDENCE PHONE [REDACTED]	BUSINESS PHONE [REDACTED]	COMMENTS			

LABOR & PARTS
J# 1 52PNZ TRIM ELECTRICAL UNITS: TECH(S): 668 0.00
TRIPOMETER INOP. CUSTOMER STATES THAT HE DROVE MILES THIS MORNING AND IT DID NOT MOVE. CHECKED TRIPOMETER FOUND NO PROBLEM.

JOB # 1 TOTAL LABOR & PARTS 0.00

J# 2 10PNZ DRIVEABILITY UNITS: 1.00 TECH(S): 668 INTERNAL
CUSTOMER STATES THAT VEHICAL IS SLIGHTLY PULLING TO THE LEFT CHECK AND ADVISE. CHARGE TO SALES. PER DOMINICK DIAGNOSED AND CHECK FRONT AND REAR SUSPENTION. ONLY PROBLEM FOUND WERE TIRES BEING "S" RATED AND SOULD BE "H" RATED. REPLACED TIRES AND RIMS TO "H" RATED

JOB # 2 TOTAL LABOR & PARTS 0.00

J# 3 11PNZ ENGINE MINOR UNITS: 0.50 TECH(S): 668 INTERNAL
CHECK FOR ENGINE OIL LEAK, DIE WAS ADDED TO SYSTEM ABOUT 3 WEEKS AGO. CHECK AND ADVISE. CHARGE TO SERVICE CHECKED ENTIRE ENGINE WITH BLACK LIGHT FOUND NO LEAKS.

JOB # 3 TOTAL LABOR & PARTS 0.00

J# 4 70PNZ03 RENTAL UNITS: TECH(S): 668 WARRANTY
RENTAL WHILE VEHICAL IS BEING SERVICED. TWO DAY RENTAL

JOB # 4 TOTAL LABOR & PARTS 0.00

J# 5 61PNZ EXTERIOR TRIM UNITS: TECH(S): 668 0.00
CUSTOMER STATES THAT AIR IS COMING IN THROUGH INTERIOR DOOR HANDLE. CHECKED FOR ANY RECALLS OR TSB'S. NO PROBLEM FOUND.

JOB # 5 TOTAL LABOR & PARTS 0.00

SUBLET	PO#	VEND INV#	INV. DATE	DESCRIPTION	WARRANTY
JOB # 4	12016		11/27/01	RENTAL	
TOTAL - SUBLET					0.00

COMMENTS
CALL

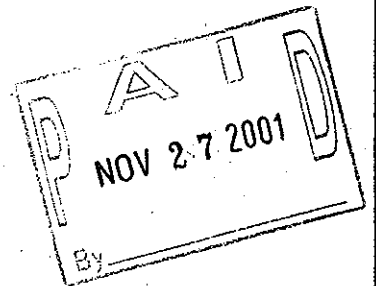

Copyright © 1998 The Reynolds and Reynolds Company EIAWTSIHE CCC26946 (10/1)



DISCLAIMER OF WARRANTIES - Any warranties on the products sold hereby are those made by the manufacturer. The Selling Dealer hereby expressly disclaims all warranties, either express or implied, including any implied warranty of merchantability or fitness for a particular purpose, and the Selling Dealer neither assumes nor authorizes any other person to assume for it any liability in connection with the sale of this part(s) and/or service. Manufacturer's warranty 12 months/12,000 miles parts and labor. Buyer shall not be entitled to recover from the Selling Dealer any consequential damages, damages to property, damages for loss of use, loss of time, loss of profit or income, or any other incidental damages.

CUSTOMER NO.	ADVISOR JEREMIAH MITRE	6907	TAG NO.	INVOICE DATE 11/27/01	INVOICE NO. PNC32262
	LABOR RATE 105.00	LICENSE NO.	MILEAGE 8,985	COLOR NAVY BLUE M	STOCK NO.
CHICAGO, IL	YEAR / MAKE / MODEL 01/PONTIAC/GRAND PRIX/2 DOOR COUPE			DELIVERY DATE 07/30/01	DELIVERY MILES 6,011
	VEHICLE I.D. NO. 1 G 2 W R 1 2 1 6 1 F			SELLING DEALER NO.	PRODUCTION DATE
	F.T.E. NO.	P.O. NO.	R.O. DATE 11/26/01		

COMMENTS

- LABOR & PARTS**
- J# 1: 52PNZ** TRIM, ELECTRICAL UNITS: TECH(S): 668 0.00
 TRIPOMETER INOP. CUSTOMER STATES THAT HE DROVE MILES THIS MORNING AND IT DID NOT MOVE. CHECKED TRIPOMETER FOUND NO PROBLEM.
 JOB # 1 TOTAL LABOR & PARTS 0.00
 - J# 2: 10PNZ** DRIVEABILITY UNITS: 1.00 TECH(S): 668 INTERNAL
 CUSTOMER STATES THAT VEHICAL IS SLIGHTLY PULLING TO THE LEFT CHECK AND ADVISE. CHARGE TO SALES. PER DOMINICK DIAGNOSED AND CHECK FRONT AND REAR SUSPENTION. ONLY PROBLEM FOUND WERE TIRES BEING "S" RATED AND SOULD BE "H" RATED. REPLACED TIRES AND RIMS TO "H" RATED
 JOB # 2 TOTAL LABOR & PARTS 0.00
 - J# 3: 11PNZ** ENGINE MINOR UNITS: 0.50 TECH(S): 668 INTERNAL
 CHECK FOR ENGINE OIL LEAK. DIE WAS ADDED TO SYSTEM ABOUT 3 WEEKS AGO. CHECK AND ADVISE. CHARGE TO SERVICE. CHECKED ENTIRE ENGINE WITH BLACK LIGHT FOUND NO LEAKS.
 JOB # 3 TOTAL LABOR & PARTS 0.00
 - J# 4: 70PNZ03** RENTAL UNITS: TECH(S): 999 WARRANTY
 RENTAL WHILE VEHICAL IS BEING SERVICED. TWO DAY RENTAL
 JOB # 4 TOTAL LABOR & PARTS 0.00
 - J# 5: 61PNZ** EXTERIOR TRIM UNITS: TECH(S): 668 0.00
 CUSTOMER STATES THAT AIR IS COMING IN THROUGH INTERIOR DOOR HANDLE. CHECKED FOR ANY RECALLS OR TSB'S. NO PROBLEM FOUND.
 JOB # 5 TOTAL LABOR & PARTS 0.00

SUBLET	PO#	VEND INV#	INV. DATE	DESCRIPTION	WARRANTY
JOB # 4	12016		11/27/01	RENTAL	
TOTAL - SUBLET					0.00

COMMENTS
 CALL





DISCLAIMER OF WARRANTIES - Any warranties on the products sold hereby are those made by the manufacturer. The Selling Dealer hereby expressly disclaims all warranties, either express or implied, including any implied warranty of merchantability or fitness for a particular purpose, and the Selling Dealer neither assumes nor authorizes any other person to assume for it any liability in connection with the sale of this part(s) and/or service. Manufacturer's warranty 12 months/12,000 miles parts and labor. Buyer shall not be entitled to recover from the Selling Dealer any consequential damages, damages to property, damages for loss of use, loss of time, loss of profit or income, or any other incidental damages.

CUSTOMER NO.	ADVISOR JEREMIAH MITRE	6907	TAG NO.	INVOICE DATE 11/27/01	INVOICE NO. PNCS32262
	LABOR RATE 105.00	LICENSE NO.	MILEAGE 8,985	COLOR NAVY BLUE M	STOCK NO.
CHICAGO, IL	YEAR / MAKE / MODEL 01/PONTIAC/GRAND PRIX/2 DOOR COUPE			DELIVERY DATE 07/30/01	DELIVERY MILES 6,011
	VEHICLE I.D. NO. 1G2WR12161F			SELLING DEALER NO.	PRODUCTION DATE
	F.T.E. NO.	P.O. NO.	P.O. DATE 11/26/01		
COMMENTS					

TOTALS

 * NEXT RECOMMENDED SERVICE: *
 * 12/04/2006 / 14985 MI 01PNZZRT TIRE ROTATE *

* [] CASH [] CHECK CK NO. [] *	TOTAL LABOR....	0.00
* [] VISA [] MASTERCARD [] DISCOVER *	TOTAL PARTS....	0.00
* [] AMER XPRESS [] OTHER [] CHARGE *	TOTAL SUBLET....	0.00
	TOTAL G.O.G....	0.00
	TOTAL MISC CHG.	0.00
	TOTAL MISC DISC	0.00
	TOTAL TAX.....	0.00
	TOTAL INVOICE \$	0.00

THANK YOU FOR YOUR BUSINESS!!

CUSTOMER SIGNATURE _____
 ***** DUPLICATE INVOICE *****



CHEVROLET



PONTIAC

GMC



BUICK



Cadillac



Goodwrench

Gillespie

PONTIAC

773 434-8200
Fax 773 434-5906



6603-33 So. Western Ave.
Chicago, Illinois 60636

DISCLAIMER OF WARRANTIES - Any warranties on the products sold hereby are those made by the manufacturer. The Selling Dealer hereby expressly disclaims all warranties, either express or implied, including any implied warranty of merchantability or fitness for a particular purpose, and the Selling Dealer neither assumes nor authorizes any other person to assume for it any liability in connection with the sale of this part(s) and/or service.
Buyer shall not be entitled to recover from the Selling Dealer any consequential damages, damages to property, damages for loss of use, loss of time, loss of profit or income, or any other incidental damages.

CUSTOMER NO.	ADVISOR JEREMIAH MITRE	TAG NO. 6907	INVOICE DATE 01/02/02	INVOICE NO. PNC333974
	LABOR RATE 80.00	LICENSE NO.	MILEAGE 10,032	COLOR NAVY BLUE M
CHICAGO, IL	YEAR / MAKE / MODEL 01/PONTIAC/GRAND PRIX/2DR CPE GTP	DELIVERY DATE 07/30/01		STOCK NO. 5360
	VEHICLE I.D. NO. 1 G 2 W R 1 2 1 6 1 F	SELLING DEALER NO.		DELIVERY MILES 6,011
	F.T.E. NO.	P.O. NO.	R.O. DATE 01/02/02	PRODUCTION DATE
RESIDENCE PHONE	BUSINESS PHONE	COMMENTS		

LABOR & PARTS
J# 1-11PNZ ENGINE MINOR UNITS: 0.50 TECH(S): 618 WARRANTY
 SERVICE ENGINE SOON LIGHT IS ON.
 REPAIRED CONNECTOR AT FUEL TANK.

JOB # 1 TOTAL LABOR & PARTS 0.00

J# 2-85PNZ13 SOUND SYSTEM UNITS: 0.50 TECH(S): 618 WARRANTY
 CUSTOMER STATES THAT E23 ERROR SHOWED UP ON RADIO AND THEN
 CDS DIDNOT WANT TO PLAY.BUT ONLY WHEN COLD.
 REMOVED AND SUBLET OUT FOR REPAIRS.

JOB # 2 TOTAL LABOR & PARTS 0.00

J# 3-70PNZ03 RENTAL UNITS: TECH(S): 999 WARRANTY
 RENTAL
 1 DAY RENTAL

JOB # 3 TOTAL LABOR & PARTS 0.00

J# 4-50PNZ01 ENGINE ELECT CONCERN UNITS: 0.70 TECH(S): 618 WARRANTY
 REFLASH PCM.
 REFLASHED PCM.

JOB # 4 TOTAL LABOR & PARTS 0.00

SUBLET PO# VEND INV# INV DATE DESCRIPTION WARRANTY
 JOB # 3 12657 01/02/02 1 DAY RENTAL \$30.00
 TOTAL - SUBLET 0.00

COMMENTS
CALL

TOTALS

 * [] CASH [] CHECK CK NO. [] *
 * [] VISA [] MASTERCARD [] DISCOVER *
 * [] AMER XPRESS [] OTHER [] CHARGE *

TOTAL LABOR....
 TOTAL PARTS....
 TOTAL SUBLET...
 TOTAL G.O.G....
 TOTAL MISC CHG.
 TOTAL MISC DISC
 TOTAL TAX.....

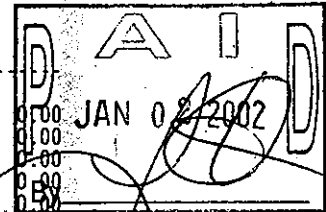

TOTAL INVOICE \$ 0.00

THANK YOU FOR YOUR BUSINESS!!

Copyright © 1998 The Reynolds and Reynolds Company. EPRINTS114E C226504 (1/01)



DISCLAIMER OF WARRANTIES - Any warranties on the products sold hereby are those made by the manufacturer. The Selling Dealer hereby expressly disclaims all warranties, either express or implied, including any implied warranty of merchantability or fitness for a particular purpose, and the Selling Dealer neither assumes nor authorizes any other person to assume for it any liability in connection with the sale of this part(s) and/or service. Manufacturer's warranty 12 months/12,000 miles parts and labor. Buyer shall not be entitled to recover from the Selling Dealer any consequential damages, damages to property, damages for loss of use, loss of time, loss of profit or income, or any other incidental damages.

CUSTOMER NO.	ADVISOR JEREMIAH MITRE	6907	TAG NO.	INVOICE DATE 01/02/02	INVOICE NO. PNCS33974
	LABOR RATE 105.00	LICENSE NO.	MILEAGE 10,032	COLOR NAVY BLUE M	STOCK NO.
CHICAGO, IL	YEAR / MAKE / MODEL 01/PONTIAC/GRAND PRIX/2 DOOR COUPE		DELIVERY DATE 07/30/01	DELIVERY MILES 6,011	
	VEHICLE I.D. NO. 1 G 2 W R 1 2 1 6 1 F		SELLING DEALER NO.	PRODUCTION DATE	
	F.T.E. NO.	P.O. NO.	R.O. DATE 01/02/02		
BUSINESS PHONE					
COMMENTS					

***** DUPLICATE INVOICE *****



CHEVROLET



PONTIAC

GMC



BUICK



Cadillac



Goodwrench



773 434-8200
Fax 773 434-5906



6603-33 So. Western Ave.
Chicago, Illinois 60636

DISCLAIMER OF WARRANTIES - Any warranties on the products sold hereby are those made by the manufacturer. The Selling Dealer hereby expressly disclaims all warranties, either express or implied, including any implied warranty of merchantability or fitness for a particular purpose, and the Selling Dealer neither assumes nor authorizes any other person to assume for it any liability in connection with the sale of this part(s) and/or service. Buyer shall not be entitled to recover from the Selling Dealer any consequential damages, damages to property, damages for loss of use, loss of time, loss of profit or income, or any other incidental damages.

CUSTOMER NO.	ADVISOR JEREMIAH MITRE	TAG NO. 6907	INVOICE DATE 01/09/02	INVOICE NO. PNCS34322
	LABOR RATE 80.00	LICENSE NO.	MILEAGE 10,245	COLOR NAVY BLUE M
	YEAR / MAKE / MODEL 01/PONTIAC/GRAND PRIX/2DR CPE GTP		DELIVERY DATE 07/30/01	STOCK NO. 5360
CHICAGO, IL	VEHICLE I.D. NO. 1 G 2 W R 1 2 1 6 1 F		SELLING DEALER NO.	DELIVERY MILES 6,011
	F.T.E. NO.	I.P.O. NO.	R.O. DATE 01/08/02	PRODUCTION DATE
RESIDENCE PHONE	BUSINESS PHONE	COMMENTS		

TOTALS

*****	TOTAL LABOR....	0.00
*	TOTAL PARTS....	0.00
* [] CASH [] CHECK CK NO. []	TOTAL SUBLET...	0.00
* [] VISA [] MASTERCARD [] DISCOVER	TOTAL G.O.G....	0.00
* [] AMER XPRESS [] OTHER [] CHARGE	TOTAL MISC CHG.	0.00
*****	TOTAL MISC DISC	0.00
	TOTAL TAX.....	0.00
	TOTAL INVOICE \$	0.00

THANK YOU FOR YOUR BUSINESS!!

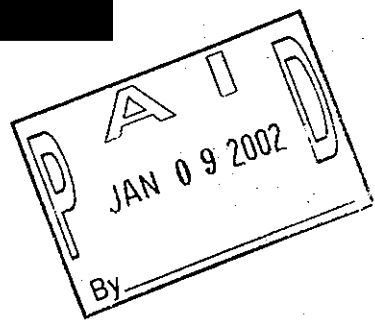
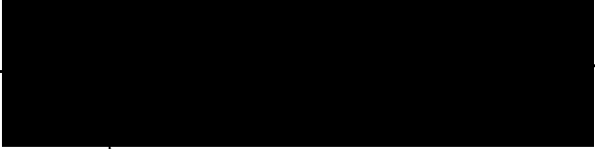

Copyright © 1998 The Reynolds and Reynolds Company E-RAINTS114E CC236504 (1/01)



773 434-8200
Fax 773 434-5906



6603-33 So. Western Ave.
Chicago, Illinois 60636

DISCLAIMER OF WARRANTIES - Any warranties on the products sold hereby are those made by the manufacturer. The Selling Dealer hereby expressly disclaims all warranties, either express or implied, including any implied warranty of merchantability or fitness for a particular purpose, and the Selling Dealer neither assumes nor authorizes any other person to assume for it any liability in connection with the sale of this part(s) and/or service.
Buyer shall not be entitled to recover from the Selling Dealer any consequential damages, damages to property, damages for loss of use, loss of time, loss of profit or income, or any other incidental damages.

CUSTOMER NO.	ADVISOR JEREMIAH MITRE	6907	TAG NO.	INVOICE DATE 01/09/02	INVOICE NO. PNCS34322
	LABOR RATE 80.00	LICENSE NO.	MILEAGE 10,245	COLOR NAVY BLUE M	STOCK NO. 5360
CHICAGO, IL	YEAR - MAKE - MODEL 01/PONTIAC/GRAND PRIX/2DR CPE GTP			DELIVERY DATE 07/30/01	DELIVERY MILES 6,011
	VEHICLE I.D. NO. 1 G 2 W R 1 2 1 6 1 F			SELLING DEALER NO.	PRODUCTION DATE
	F. T. E. NO.	P. O. NO.	R. O. DATE 01/08/02		
RESIDENCE PHONE	BUSINESS PHONE	COMMENTS			

LABOR & PARTS
J# 1 11PNZ ENGINE MINOR UNITS: 0.60 TECH(S): 618 WARRANTY
 SERVICE ENGINE SOON LIGHT IS ON.
 DIAGNOSED AND REPLACED EGR VALVE AND GASKET.
 TEST DROVE FOR TEN MILES LIGHT NEVER CAME BACK ON.

PARTS	QTY	FP-NUMBER	DESCRIPTION	UNIT PRICE	WARRANTY
JOB # 1	1	12570094	VALVE 3.670		WARRANTY
JOB # 1	1	12567275	GASKET 3.680		WARRANTY
JOB # 1 TOTAL PARTS				0.00	
JOB # 1 TOTAL LABOR & PARTS				0.00	

J# 2 85PNZ ACCESSORIES UNITS: 0.20 TECH(S): 619 WARRANTY
 INSTALL RADIO.
 REINSTALLED RADIO

PARTS	QTY	FP-NUMBER	DESCRIPTION	UNIT PRICE	WARRANTY
JOB # 2 TOTAL PARTS				0.00	
JOB # 2 TOTAL LABOR & PARTS				0.00	

J# 3 70PNZ03 RENTAL UNITS: 1 TECH(S): 999 WARRANTY
 RENTAL
 1 DAY RENTAL

PARTS	QTY	FP-NUMBER	DESCRIPTION	UNIT PRICE	WARRANTY
JOB # 3 TOTAL PARTS				0.00	
JOB # 3 TOTAL LABOR & PARTS				0.00	

SUBLET PO# VEND INV# INV. DATE DESCRIPTION WARRANTY
 JOB # 3 12825 01/09/02 RENTAL TOTAL - SUBLET 0.00

COMMENTS
 CALL

Copyright © 1998 The Reynolds and Reynolds Company ERMNTS11AE 0228804 (1/01)

Gillespie



GM SERVICE CENTER

6603-33 So. Western Ave.
 Chicago, Illinois 60636
 773 434-8200
 Fax 773 470-2790
 www.gillespieautogroup.com



DISCLAIMER OF WARRANTIES - Any warranties on the products sold hereby are those made by the manufacturer. The Selling Dealer hereby expressly disclaims all warranties, either express or implied, including any implied warranty of merchantability or fitness for a particular purpose, and the Selling Dealer neither assumes nor authorizes any other person to assume for it any liability in connection with the sale of this part(s) and/or service. Manufacturer's warranty 12 months/12,000 miles parts and labor. Buyer shall not be entitled to recover from the Selling Dealer any consequential damages, damages to property, damages for loss of use, loss of time, loss of profit or income, or any other incidental damages.

CUSTOMER NO.	ADVISOR JEREMIAH MITRE	TAG NO. 6907	INVOICE DATE 01/09/02	INVOICE NO. PNC534322
CHICAGO, IL	LABOR RATE 105.00	LICENSE NO.	MILEAGE 10,245	COLOR NAVY BLUE M
	YEAR / MAKE / MODEL 01/PONTIAC/GRAND PRIX/2 DOOR COUPE		DELIVERY DATE 07/30/01	DELIVERY MILES 6,011
	VEHICLE I.D. NO. 1 G 2 W R 1 2 1 6 1 F		SELLING DEALER NO.	PRODUCTION DATE
	F.T.E. NO.	P.O. NO.	R.O. DATE 01/08/02	
COMMENTS				

LABOR & PARTS
 # 1-81PNZ ENGINE MINOR UNITS: 0.60 TECH(S): 618 WARRANTY
 SERVICE ENGINE SOON LIGHT IS ON.
 DIAGNOSED AND REPLACED EGR VALVE AND GASKET.
 TEST DROVE FOR TEN MILES LIGHT NEVER CAME BACK ON.

PARTS	QTY	FP-NUMBER	DESCRIPTION	UNIT PRICE	WARRANTY
JOB # 1	1	12570094	VALVE	3.670	WARRANTY
JOB # 1	1	12567275	GASKET	3.680	WARRANTY
				JOB # 1 TOTAL PARTS	0.00
				JOB # 1 TOTAL LABOR & PARTS	0.00

2-85PNZ ACCESSORIES UNITS: 0.20 TECH(S): 618 WARRANTY
 INSTALL RADIO.
 REINSTALLED RADIO

PARTS	QTY	FP-NUMBER	DESCRIPTION	UNIT PRICE	WARRANTY
				JOB # 2 TOTAL PARTS	0.00
				JOB # 2 TOTAL LABOR & PARTS	0.00

3-70PNZ08 RENTAL UNITS: TECH(S): 999 WARRANTY
 RENTAL
 1 DAY RENTAL

PARTS	QTY	FP-NUMBER	DESCRIPTION	UNIT PRICE	WARRANTY
				JOB # 3 TOTAL PARTS	0.00
				JOB # 3 TOTAL LABOR & PARTS	0.00

SUBLET	PO#	VEND INV#	INV. DATE	DESCRIPTION	WARRANTY
JOB # 3	12825		01/09/02	RENTAL	0.00
				TOTAL - SUBLET	0.00

COMMENTS:
 CALL

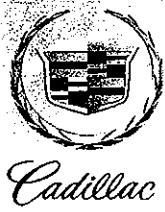

Reynolds and Reynolds ERAINTS14E FL009266 O (0306)



DISCLAIMER OF WARRANTIES - Any warranties on the products sold hereby are those made by the manufacturer. The Selling Dealer hereby expressly disclaims all warranties, either express or implied, including any implied warranty of merchantability or fitness for a particular purpose, and the Selling Dealer neither assumes nor authorizes any other person to assume for it any liability in connection with the sale of this part(s) and/or service. Manufacturer's warranty 12 months/12,000 miles parts and labor. Buyer shall not be entitled to recover from the Selling Dealer any consequential damages, damages to property, damages for loss of use, loss of time, loss of profit or income, or any other incidental damages.

CUSTOMER NO.	ADVISOR JEREMIAH MITRE	6907	TAG NO.	INVOICE DATE 01/09/02	INVOICE NO. PNC534322
CHICAGO, IL	LABOR RATE 105.00	LICENSE NO.	MILEAGE 10,245	COLOR NAVY BLUE M	STOCK NO.
	YEAR / MAKE / MODEL 01/PONTIAC/GRAND PRIX/2 DOOR COUPE			DELIVERY DATE 07/30/01	DELIVERY MILES 6,011
	VEHICLE I.D. NO. 1 G 2 W R 1 2 1 6 1 F			SELLING DEALER NO.	PRODUCTION DATE
	F.T.E. NO.		P.O. NO.	R.P. DATE 01/08/02	
COMMENTS					

TOTALS

 * NEXT RECOMMENDED SERVICE: *
 * 12/05/2006 / 11029 MI 01PNZZRT TIRE ROTATE *

*****	TOTAL LABOR....	0.00
* [] CASH [] CHECK CK NO. [] *	TOTAL PARTS....	0.00
* [] VISA [] MASTERCARD [] DISCOVER *	TOTAL SUBLET...	0.00
* [] AMER XPRESS [] OTHER [] CHARGE *	TOTAL G.O.G....	0.00
*****	TOTAL MISC CHG.	0.00
	TOTAL MISC DISC	0.00
	TOTAL TAX.....	0.00
	TOTAL INVOICE \$	0.00

THANK YOU FOR YOUR BUSINESS!!

CUSTOMER SIGNATURE _____
 ***** DUPLICATE INVOICE *****

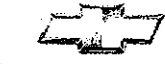

CHEVROLET



PONTIAC

GMC



BUICK



Cadillac



Goodwrench



GM SERVICE CENTER

6603-33 So. Western Ave.
 Chicago, Illinois 60636
 773 434-8200
 Fax 773 434-5906
 www.gillespieautogroup.com



DISCLAIMER OF WARRANTIES - Any warranties on the products sold hereby are those made by the manufacturer. The Selling Dealer hereby expressly disclaims all warranties, either express or implied, including any implied warranty of merchantability or fitness for a particular purpose, and the Selling Dealer neither assumes nor authorizes any other person to assume for it any liability in connection with the sale of this part(s) and/or service. Manufacturer's warranty 12 months/12,000 miles parts and labor. Buyer shall not be entitled to recover from the Selling Dealer any consequential damages, damages to property, damages for loss of use, loss of time, loss of profit or income, or any other incidental damages.

CUSTOMER NO. [REDACTED]	ADVISOR JEREMIAH MITRE	TAG NO. 6907	INVOICE DATE 10/25/02	INVOICE NO. PNCS49105
[REDACTED]	LABOR RATE 85.00	LICENSE NO.	MILEAGE 17,225	COLOR NAVY BLUE M
CHICAGO, IL [REDACTED]	YEAR / MAKE / MODEL 01 / PONTIAC / GRAND PRIX / 2DR CPE GTP	VEHICLE I.D. NO. 1G2WR12161E [REDACTED]	DELIVERY DATE 07/30/01	STOCK NO. 5360
[REDACTED]	R.O. DATE 10/23/02	DELIVERY MILES 6,011	SELLING DEALER NO.	PRODUCTION DATE
RESIDENCE PHONE [REDACTED]	BUSINESS PHONE [REDACTED]	COMMENTS		

TOTALS

 * [] CASH [] CHECK CK NO. [] *
 * [] VISA [] MASTERCARD [] DISCOVER *
 * [] AMER XPRESS [] OTHER [] CHARGE *

TOTAL LABOR.... 29.99
 TOTAL PARTS.... 0.00
 TOTAL SUBLET... 0.00
 TOTAL G.O.G.... 0.00
 TOTAL MISC CHG. 0.00
 TOTAL MISC DISC 0.00
 TOTAL TAX..... 0.00

TOTAL INVOICE \$ 29.99

THANK YOU FOR YOUR BUSINESS!!

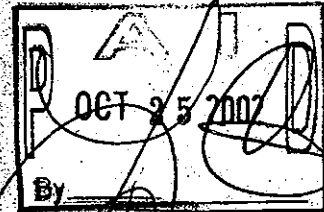



GM SERVICE CENTER

6603-33 So. Western Ave.
Chicago, Illinois 60636
773 434-8200
Fax 773 434-5906



www.gillespieautogroup.com

DISCLAIMER OF WARRANTIES - Any warranties on the products sold hereby are those made by the manufacturer. The Selling Dealer hereby expressly disclaims all warranties, either express or implied, including any implied warranty of merchantability or fitness for a particular purpose, and the Selling Dealer neither assumes nor authorizes any other person to assume for it any liability in connection with the sale of this part(s) and/or service. Manufacturer's warranty 12 months/12,000 miles parts and labor. Buyer shall not be entitled to recover from the Selling Dealer any consequential damages, damages to property, damages for loss of use, loss of time, loss of profit or income, or any other incidental damages.

CUSTOMER NO. [REDACTED]	ADVISOR JEREMIAH MITRE	TAG NO. 6907	INVOICE DATE 10/25/02	INVOICE NO. PNCS49105
[REDACTED]	LABOR RATE 85.00	LICENSE NO.	COLOR NAVY BLUE M	STOCK NO. 5360
[REDACTED]	YEAR / MAKE / MODEL 01 / PONTIAC / GRAND PRIX / 2DR CPE GTP	MILEAGE 17,225	DELIVERY DATE 07/30/01	DELIVERY MILES 6,011
CHICAGO, IL	VEHICLE I.D. NO. 1G2WR12161E	P.O. NO.	SELLING DEALER NO.	PRODUCTION DATE
RESIDENCE PHONE [REDACTED]	BUSINESS PHONE [REDACTED]	COMMENTS	R.O. DATE 10/23/02	

LABOR & PARTS
J# 6 61PNZ EXTERIOR TRIM UNITS TECH(S) 668 0:00
DRIVER SIDE FRONT DOOR PANEL IS FALLING OFF.
PARTS HAVE BEEN SPECIAL ORDERED FOR YOUR VEHICLE.
DRIVER SIDE DOOR MOLDING.

PARTS	QTY	FP-NUMBER	DESCRIPTION	UNIT PRICE
			JOB # 6 TOTAL PARTS	0.00
			JOB # 6 TOTAL LABOR & PARTS	0.00

J# 7 60PNZ01 INT TRIM CONCERN UNITS TECH(S) 668 0:00
CUSTOMER STATES THAT REAR SEAT CENTER ARM REST KEEPS FALLING OUT.
CANNOT DUPLICATE CUSTOMER CONCERN AT THIS TIME.

PARTS	QTY	FP-NUMBER	DESCRIPTION	UNIT PRICE
			JOB # 7 TOTAL PARTS	0.00
			JOB # 7 TOTAL LABOR & PARTS	0.00

J# 8 70PNZ03 RENTAL UNITS TECH(S) 668 WARRANTY
RENTAL
THREE DAYS RENTAL

PARTS	QTY	FP-NUMBER	DESCRIPTION	UNIT PRICE
			JOB # 8 TOTAL PARTS	0.00
			JOB # 8 TOTAL LABOR & PARTS	0.00

J# 9+01PNZZRT TIRE ROTATE UNITS TECH(S) 668
Added Operation (JERRY @ 10/25/2002 15:12)
CUSTOMER REQUEST TIRE ROTATE
TIRE MAINTENANCE
ROTATE TIRES INSPECT FOR WEAR

PARTS	QTY	FP-NUMBER	DESCRIPTION	UNIT PRICE
			JOB # 9 TOTAL PARTS	0.00
			JOB # 9 TOTAL LABOR & PARTS	29.99

SUBLET	PO#	VEND INV#	INV. DATE	DESCRIPTION	WARRANTY
JOB # 1	17861		10/25/02	SUNROOF	WARRANTY
JOB # 8	17856		10/25/02	RENTAL	WARRANTY
TOTAL - SUBLET					0.00

COMMENTS
CALL



GM SERVICE CENTER

6603-33 So. Western Ave.
 Chicago, Illinois 60636
 773 434-8200
 Fax 773 434-5906
 www.gillespieautogroup.com



DISCLAIMER OF WARRANTIES - Any warranties on the products sold hereby are those made by the manufacturer. The Selling Dealer hereby expressly disclaims all warranties, either express or implied, including any implied warranty of merchantability or fitness for a particular purpose, and the Selling Dealer neither assumes nor authorizes any other person to assume for it any liability in connection with the sale of this part(s) and/or service. Manufacturer's warranty 12 months/12,000 miles parts and labor. Buyer shall not be entitled to recover from the Selling Dealer any consequential damages, damages to property, damages for loss of use, loss of time, loss of profit or income, or any other incidental damages.

CUSTOMER NO.	ADVISOR JEREMIAH MITRE	TAG NO.	INVOICE DATE 10/25/02	INVOICE NO. PNCS49105
	LABOR RATE 85.00	LICENSE NO.	COLOR NAVY BLUE M	STOCK NO. 5360
	YEAR / MAKE / MODEL 01/PONTIAC/GRAND PRIX/2DR CPE GTP	MILEAGE 17,225	DELIVERY DATE 07/30/01	DELIVERY MILES 6,011
CHICAGO, IL	VEHICLE I.D. NO. 1G2WR12161E	P.O. NO.	SELLING DEALER NO.	PRODUCTION DATE
RESIDENCE PHONE	BUSINESS PHONE	COMMENTS	R.O. DATE 10/23/02	

LABOR & PARTS
 # 1 60PNZ INTERIOR TRIM UNITS: 1.70 TECH(S): 999 WARRANTY
 CUSTOMER STATES THAT WATER IS LEAKING IN THROUGH SUNROOF.
 NOTE: ON PASSENGER SIDE FRONT.
 DIAGNOSED AND SUBLET OUT TO TRIM SHOP AND UNCLOGGED SUNROOF ASSEMBLY.

PARTS	QTY	FP-NUMBER	DESCRIPTION	UNIT PRICE
			JOB # 1 TOTAL PARTS	0.00
			JOB # 1 TOTAL LABOR & PARTS	0.00

2 85PNZ ACCESSORIES UNITS: 1.00 TECH(S): 000 WARRANTY
 CUSTOMER STATES THAT CD PLAYER READS E20 AND CUSTOMER ALSO STATES THAT CD'S SKIP WHEN HITTING BUMPS.
 DIAGNOSED AND REMOVED RADIO AND SENT OUT FOR REPAIRS.

PARTS	QTY	FP-NUMBER	DESCRIPTION	UNIT PRICE
			JOB # 2 TOTAL PARTS	0.00
			JOB # 2 TOTAL LABOR & PARTS	0.00

3 10PNZ DRIVEABILITY UNITS: 1.00 TECH(S): 668 WARRANTY
 CUSTOMER STATES THAT VEHICLE DRIFTS TO THE LEFT MAINLEY ON HIGHWAY SPEEDS.
 DIGNOSED AND REPLACED LEFT OUTER TIE ROD END AND ADJUSTED TOE TO SPECS.

PARTS	QTY	FP-NUMBER	DESCRIPTION	UNIT PRICE
JOB # 3	1	26086579	ROD KIT 6.233	
			JOB # 3 TOTAL PARTS	0.00
			JOB # 3 TOTAL LABOR & PARTS	0.00

4 10PNZ01 DRIVEABILITY CONCERN UNITS: 1.00 TECH(S): 668 WARRANTY
 CUSTOMER STATES HE HEARS A KNOCKING NOISE IN DRIVER SIDE FRONTEND.
 AFTERMARKET AIR INTAKE SYSTEM INSTALLED INTO VEHICLE CAUSING PCM TO BOUNCE AROUND WITH BUNGIE CORD HOLDING IT DOWN.

PARTS	QTY	FP-NUMBER	DESCRIPTION	UNIT PRICE
			JOB # 4 TOTAL PARTS	0.00
			JOB # 4 TOTAL LABOR & PARTS	0.00

5 45PNZ01 STEERING CONCERN UNITS: 1.00 TECH(S): 668 WARRANTY
 CUSTOMER STATES THAT HE HEARS A MOANING NOISE WHEN TURNING LEFT OR RIGHT QUICK TURNS OR PARKING.
 CANNOT DUPLICATE CUSTOMER CONCERN AT THIS TIME.

PARTS	QTY	FP-NUMBER	DESCRIPTION	UNIT PRICE
			JOB # 5 TOTAL PARTS	0.00
			JOB # 5 TOTAL LABOR & PARTS	0.00



DISCLAIMER OF WARRANTIES - Any warranties on the products sold hereby are those made by the manufacturer. The Selling Dealer hereby expressly disclaims all warranties, either express or implied, including any implied warranty of merchantability or fitness for a particular purpose, and the Selling Dealer neither assumes nor authorizes any other person to assume for it any liability in connection with the sale of this part(s) and/or service. Manufacturer's warranty 12 months/12,000 miles parts and labor. Buyer shall not be entitled to recover from the Selling Dealer any consequential damages, damages to property, damages for loss of use, loss of time, loss of profit or income, or any other incidental damages.

CUSTOMER NO.	ADVISOR JEREMIAH MITRE	6907	TAG NO.	INVOICE DATE 10/25/02	INVOICE NO. PNC549105
	LABOR RATE 105.00	LICENSE NO.	MILEAGE 17,225	COLOR NAVY BLUE M	STOCK NO.
CHICAGO, IL	YEAR / MAKE / MODEL 01/PONTIAC/GRAND PRIX/2 DOOR COUPE			DELIVERY DATE 07/30/01	DELIVERY MILES 6,011
	VEHICLE I.D. NO. 1 G 2 W R 1 2 1 6 1 F			SELLING DEALER NO.	PRODUCTION DATE
	F.T.E. NO.	P.O. NO.		R.O. DATE 10/23/02	
COMMENTS					

LABOR & PARTS
J# 1: 60PNZ INTERIOR TRIM UNITS: 1 TECH(S): 999 WARRANTY
 CUSTOMER STATES THAT WATER IS LEAKING IN THROUGH SUNROOF.
 NOTE: ON PASSENGER SIDE FRONT.
 DIAGNOSED AND SUBLET OUT TO TRIM SHOP AND UNCLOGGED SUNROOF ASSEMBLY.

PARTS	QTY	FP-NUMBER	DESCRIPTION	UNIT PRICE
			JOB # 1 TOTAL PARTS	0.00
			JOB # 1 TOTAL LABOR & PARTS	0.00

J# 2: 85PNZ ACCESSORIES UNITS: 1 TECH(S): 668 WARRANTY
 CUSTOMER STATES THAT CD PLAYER READS E20 AND CUSTOMER ALSO STATES THAT CD'S SKIP WHEN HITTING BUMPS.
 DIAGNOSED AND REMOVED RADIO AND SENT OUT FOR REPAIRS.

PARTS	QTY	FP-NUMBER	DESCRIPTION	UNIT PRICE
			JOB # 2 TOTAL PARTS	0.00
			JOB # 2 TOTAL LABOR & PARTS	0.00

J# 3: 10PNZ STEERING CONCERN UNITS: 1 TECH(S): 668 WARRANTY
 CUSTOMER STATES THAT VEHICLE DRIFTS TO THE LEFT MAINLY ON HIGHWAY SPEEDS.
 DIAGNOSED AND REPLACED LEFT OUTER TIE ROD END AND ADJUSTED TOE TO SPECS.

PARTS	QTY	FP-NUMBER	DESCRIPTION	UNIT PRICE
JOB # 3	1	26086579	ROD KIT 6.233	
			JOB # 3 TOTAL PARTS	0.00
			JOB # 3 TOTAL LABOR & PARTS	0.00

J# 4: 10PNZ DRIVEABILITY CONCERN UNITS: 1 TECH(S): 999
 CUSTOMER STATES HE HEARS A KNOCKING NOISE IN DRIVER SIDE FRONTEND.
 AFTERMARKET AIR INTAKE SYSTEM INSTALLED INTO VEHICLE CAUSING PCM TO BOUNCE AROUND WITH BUNGIE CORD HOLDING IT DOWN.

PARTS	QTY	FP-NUMBER	DESCRIPTION	UNIT PRICE
			JOB # 4 TOTAL PARTS	0.00
			JOB # 4 TOTAL LABOR & PARTS	0.00

J# 5: 45PNZ STEERING CONCERN UNITS: 1 TECH(S): 668
 CUSTOMER STATES THAT HE HEARS A MOANING NOISE WHEN TURNING LEFT OR RIGHT QUICK TURNS OR PARKING.
 CANNOT DUPLICATE CUSTOMER CONCERN AT THIS TIME.

PARTS	QTY	FP-NUMBER	DESCRIPTION	UNIT PRICE
			JOB # 5 TOTAL PARTS	0.00
			JOB # 5 TOTAL LABOR & PARTS	0.00



Keynolds and Reynolds, ERANTS14E FL09288 O (03/05)



DISCLAIMER OF WARRANTIES - Any warranties on the products sold hereby are those made by the manufacturer. The Selling Dealer hereby expressly disclaims all warranties, either express or implied, including any implied warranty of merchantability or fitness for a particular purpose, and the Selling Dealer neither assumes nor authorizes any other person to assume for it any liability in connection with the sale of this part(s) and/or service. Manufacturer's warranty 12 months/12,000 miles parts and labor. Buyer shall not be entitled to recover from the Selling Dealer any consequential damages, damages to property, damages for loss of use, loss of time, loss of profit or income, or any other incidental damages.

CUSTOMER NO.	ADVISOR JEREMIAH MITRE	6907	TAG NO.	INVOICE DATE 10/25/02	INVOICE NO. PNC549105
	LABOR RATE 105.00	LICENSE NO.	MILEAGE 17,225	COLOR NAVY BLUE M	STOCK NO.
CHICAGO, IL	YEAR / MAKE / MODEL 01/PONTIAC/GRAND PRIX/2 DOOR COUPE			DELIVERY DATE 07/30/01	DELIVERY MILES 6,011
	VEHICLE I.D. NO. 1 G 2 W R 1 2 1 6 1 F			SELLING DEALER NO.	PRODUCTION DATE
	F.T.E. NO.	P.O. NO.	R.O. DATE 10/23/02		
COMMENTS					

LABOR & PARTS
J# 6 61PNZ EXTERIOR TRIM UNITS: TECH(S): 668 0.00
 DRIVER SIDE FRONT DOOR PANEL IS FALLING OFF.
 PARTS HAVE BEEN SPECIAL ORDERED FOR YOUR VEHICLE.
 DRIVER SIDE DOOR MOLDING.

PARTS	QTY	FP-NUMBER	DESCRIPTION	UNIT PRICE
				JOB # 6 TOTAL PARTS 0.00
				JOB # 6 TOTAL LABOR & PARTS 0.00

J# 7 60PNZ01 INT TRIM CONCERN UNITS: TECH(S): 668 0.00
 CUSTOMER STATES THAT REAR SEAT CENTER ARM REST KEEPS FALLING OUT.
 CANNOT DUPLICATE CUSTOMER CONCERN AT THIS TIME.

PARTS	QTY	FP-NUMBER	DESCRIPTION	UNIT PRICE
				JOB # 7 TOTAL PARTS 0.00
				JOB # 7 TOTAL LABOR & PARTS 0.00

J# 8 70PNZ001 RENTAL UNITS: TECH(S): 668 WARRANTY
 RENTAL
 THREE DAYS RENTAL

PARTS	QTY	FP-NUMBER	DESCRIPTION	UNIT PRICE
				JOB # 8 TOTAL PARTS 0.00
				JOB # 8 TOTAL LABOR & PARTS 0.00

J# 9 91PNZRT TIRE ROTATE UNITS: TECH(S): 668 29.99
 CUSTOMER REQUEST TIRE ROTATE
 TIRE MAINTENANCE
 ROTATE TIRES INSPECT FOR WEAR

PARTS	QTY	FP-NUMBER	DESCRIPTION	UNIT PRICE
				JOB # 9 TOTAL PARTS 0.00
				JOB # 9 TOTAL LABOR & PARTS 29.99

SUBLET	PO#	VEND INV#	INV DATE	DESCRIPTION	WARRANTY
JOB # 1	17861		10/25/02	SUNROOF	WARRANTY
JOB # 8	17856		10/25/02	RENTAL	WARRANTY
TOTAL - SUBLET					0.00

COMMENTS
CALL



Reynolds and Reynolds ERANTS/14E FL00286 G (03/00)



DISCLAIMER OF WARRANTIES - Any warranties on the products sold hereby are those made by the manufacturer. The Selling Dealer hereby expressly disclaims all warranties, either express or implied, including any implied warranty of merchantability or fitness for a particular purpose, and the Selling Dealer neither assumes nor authorizes any other person to assume for it any liability in connection with the sale of this part(s) and/or service. Manufacturer's warranty 12 months/12,000 miles parts and labor. Buyer shall not be entitled to recover from the Selling Dealer any consequential damages, damages to property, damages for loss of use, loss of time, loss of profit or income, or any other incidental damages.

CUSTOMER NO.	ADVISOR JEREMIAH MITRE	TAG NO. 6907	INVOICE DATE 10/25/02	INVOICE NO. PNC549105
LABOR RATE 105.00	LICENSE NO.	MILEAGE 17,225	COLOR NAVY BLUE M	STOCK NO.
YEAR / MAKE / MODEL 01/PONTIAC/GRAND PRIX/2 DOOR COUPE	VEHICLE I.D. NO. 1 G 2 W R 1 2 1 6 1 F		DELIVERY DATE 07/30/01	DELIVERY MILES 6,011
CHICAGO, IL	F.T.E. NO.	P.O. NO.	SELLING DEALER NO.	PRODUCTION DATE
			R.O. DATE 10/23/02	
COMMENTS				

TOTALS

 * NEXT RECOMMENDED SERVICE: *
 * 12/06/2006 / 26295 MI 00PNZFC FUEL INJECTION FLUSH *

TOTAL LABOR....	29.99
TOTAL PARTS....	0.00
TOTAL SUBLET....	0.00
TOTAL G.O.G....	0.00
TOTAL MISC CHG.	0.00
TOTAL MISC DISC.	0.00
TOTAL TAX.....	0.00
TOTAL INVOICE \$	29.99

THANK YOU FOR YOUR BUSINESS!!

CUSTOMER SIGNATURE _____
 ***** DUPLICATE INVOICE *****





GM SERVICE CENTER

6603-33 So. Western Ave.
 Chicago, Illinois 60636
 773 434-8200
 Fax 773 434-5906



www.gillespieautogroup.com

DISCLAIMER OF WARRANTIES - Any warranties on the products sold hereby are those made by the manufacturer. The Selling Dealer hereby expressly disclaims all warranties, either express or implied, including any implied warranty of merchantability or fitness for a particular purpose, and the Selling Dealer neither assumes nor authorizes any other person to assume for it any liability in connection with the sale of this part(s) and/or service. Manufacturer's warranty 12 months/12,000 miles parts and labor. Buyer shall not be entitled to recover from the Selling Dealer any consequential damages, damages to property, damages for loss of use, loss of time, loss of profit or income, or any other incidental damages.

CUSTOMER NO. [REDACTED]	ADVISOR JEREMIAH MITRE	TAG NO. [REDACTED]	INVOICE DATE 11/01/02	INVOICE NO. PNCS49545
[REDACTED]	LABOR RATE 85.00	LICENSE NO. 6907	COLOR NAVY BLUE M	STOCK NO. 5360
[REDACTED]	YEAR / MAKE / MODEL 01/PONTIAC/GRAND PRIX/2DR CPE GTP	MILEAGE 17,407	DELIVERY DATE 07/30/01	DELIVERY MILES 6,011
CHICAGO, IL	VEHICLE I.D. NO. 1G2WR12161F	P.O. NO. [REDACTED]	SELLING DEALER NO.	PRODUCTION DATE
RESIDENCE PHONE [REDACTED]	BUSINESS PHONE [REDACTED]	COMMENTS	R.O. DATE 11/01/02	

LABOR & PARTS
 # 1 85PNZ ACCESSORIES UNITS: 0.30 TECH(S): 618 WARRANTY
 CD PLAYER INOP. INSTALL SOP RADIO.
 REINSTALLED RADIO.

PARTS	QTY	FP-NUMBER	DESCRIPTION	UNIT PRICE	
			JOB # 1 TOTAL PARTS	0.00	
			JOB # 1 TOTAL LABOR & PARTS	0.00	

2 11PNZ ENGINE MINOR UNITS: 0.00 TECH(S): 618 WARRANTY
 ENGINE MAKING A ROARING NOISE.
 DIAGNOSED AND REPLACED ALTERNATOR.

PARTS	QTY	FP-NUMBER	DESCRIPTION	UNIT PRICE	WARRANTY
JOB # 2	1	10464448	GEN REM 2.275		
JOB # 2	-1	10464448	CORE RETURN		
			JOB # 2 TOTAL PARTS	0.00	
			JOB # 2 TOTAL LABOR & PARTS	0.00	

COMMENTS
 WAITER

TOTALS

TOTAL LABOR	0.00
TOTAL PARTS	0.00
TOTAL SUBLET	0.00
TOTAL G.O.G.	0.00
TOTAL MISC CHG.	0.00
TOTAL MISC DISC.	0.00
TOTAL TAX	0.00

TOTAL INVOICE \$ 0.00

THANK YOU FOR YOUR BUSINESS!!
 [REDACTED]

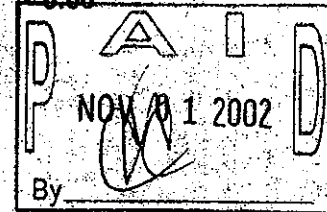



GM SERVICE CENTER

6603-33 So. Western Ave.
 Chicago, Illinois 60636
 773 434-8200
 Fax 773 470-2790
 www.gillespieautogroup.com



DISCLAIMER OF WARRANTIES - Any warranties on the products sold hereby are those made by the manufacturer. The Selling Dealer hereby expressly disclaims all warranties, either express or implied, including any implied warranty of merchantability or fitness for a particular purpose, and the Selling Dealer neither assumes nor authorizes any other person to assume for it any liability in connection with the sale of this part(s) and/or service. Manufacturer's warranty 12 months/12,000 miles parts and labor. Buyer shall not be entitled to recover from the Selling Dealer any consequential damages, damages to property, damages for loss of use, loss of time, loss of profit or income, or any other incidental damages.

CUSTOMER NO.	ADVISOR JEREMIAH MITRE	6907	TAG NO.	INVOICE DATE 11/01/02	INVOICE NO. PNCS49545
	LABOR RATE 105.00	LICENSE NO.	MILEAGE 17,407	COLOR NAVY BLUE M	STOCK NO.
CHICAGO, IL	YEAR / MAKE / MODEL 01/PONTIAC/GRAND PRIX/2 DOOR COUPE			DELIVERY DATE 07/30/01	DELIVERY MILES 6,011
	VEHICLE I.D. NO. 1 G 2 W R 1 2 1 6 1 F			SELLING DEALER NO.	PRODUCTION DATE
	F.T.E. NO.	P.O. NO.	R.O. DATE 11/01/02		
COMMENTS					

LABOR & PARTS
 # 1 85PNZ ACCESSORIES UNITS: 0.30 TECH(S) 618 WARRANTY
 CD PLAYER INOP. INSTALL SOP RADIO.
 REINSTALLED RADIO.

PARTS	QTY	FP-NUMBER	DESCRIPTION	UNIT PRICE	WARRANTY
				JOB # 1 TOTAL PARTS	0.00
				JOB # 1 TOTAL LABOR & PARTS	0.00

2 11PNZ ENGINE MINOR UNITS: 0.30 TECH(S) 618 WARRANTY
 ENGINE MAKING A ROARING NOISE.
 DIAGNOSED AND REPLACED ALTIMATOR.

PARTS	QTY	FP-NUMBER	DESCRIPTION	UNIT PRICE	WARRANTY
JOB # 2	1	10464448	GEN REM 2.275		
JOB # 2	-1	10464448	CORE RETURN		
				JOB # 2 TOTAL PARTS	0.00
				JOB # 2 TOTAL LABOR & PARTS	0.00

COMMENTS
 WAITER

TOTALS

 * NEXT RECOMMENDED SERVICE: *
 * 12/08/2006 / 18151 MI 01PNZZRT TIRE ROTATE *

*****	TOTAL LABOR....	0.00
*	TOTAL PARTS....	0.00
*	TOTAL SUBLET....	0.00
*	TOTAL G.O.G....	0.00
*	TOTAL MISC CHG	0.00
*	TOTAL MISC DISC	0.00
*	TOTAL TAX	0.00
*****	TOTAL INVOICE \$	0.00

THANK YOU FOR YOUR BUSINESS!!

CUSTOMER SIGNATURE _____
 ***** DUPLICATE INVOICE *****



Reynolds and Reynolds, ERANTSI14E, F160265 0, 03/16/01



GM SERVICE CENTER

6603-33 So. Western Ave.
 Chicago, Illinois 60636
 773 434-8200
 Fax 773 434-5906
 www.gillespieautogroup.com



DISCLAIMER OF WARRANTIES - Any warranties on the products sold hereby are those made by the manufacturer. The Selling Dealer hereby expressly disclaims all warranties, either express or implied, including any implied warranty of merchantability or fitness for a particular purpose, and the Selling Dealer neither assumes nor authorizes any other person to assume for it any liability in connection with the sale of this part(s) and/or service. Manufacturer's warranty 12 months/12,000 miles parts and labor. Buyer shall not be entitled to recover from the Selling Dealer any consequential damages, damages to property, damages for loss of use, loss of time, loss of profit or income, or any other incidental damages.

CUSTOMER NO.	ADVISOR JEREMIAH MITRE	TAG NO. 6907	INVOICE DATE 11/07/02	INVOICE NO. PNCS49875
	LABOR RATE 85.00	LICENSE NO.	MILEAGE 17,587	COLOR NAVY BLUE M
	YEAR / MAKE / MODEL 01/PONTIAC/GRAND PRIX/2DR CPE GTP		DELIVERY DATE 07/30/01	STOCK NO. 5360
CHICAGO, IL	VEHICLE I.D. NO. 1G2WR12161E		SELLING DEALER NO.	DELIVERY MILES 6,011
	F.T.E. NO.	P.O. NO.	R.O. DATE 11/07/02	PRODUCTION DATE
RESIDENCE PHONE	BUSINESS PHONE	COMMENTS		

LABOR & PARTS
 # 1 61PNZ EXTERIOR TRIM UNITS TECH(S): 620 WARRANTY
 DOOR MOLDING FALLING OFF, INSTALL SOP MOLDINGS.
 REPLACED DRIVER DOOR MOLDING.

PARTS	QTY	FP NUMBER	DESCRIPTION	UNIT PRICE	WARRANTY
JOB # 1	1	12455145	MLDG-F/SD 12.112	JOB # 1 TOTAL PARTS	0.00
				JOB # 1 TOTAL LABOR & PARTS	0.00

SUBLET	PO#	VEND INV#	INV DATE	DESCRIPTION	WARRANTY
JOB # 1	18125		11/07/02	PAINT MLDG	0.00
				TOTAL - SUBLET	0.00

COMMENTS
 WAITER

TOTALS

TOTAL LABOR.....	0.00
TOTAL PARTS.....	0.00
TOTAL SUBLET.....	0.00
TOTAL G.O.G.....	0.00
TOTAL MISC CHG.....	0.00
TOTAL MISC DISC.....	0.00
TOTAL TAX.....	0.00
TOTAL INVOICE \$	0.00

THANK YOU FOR YOUR BUSINESS!!



IMPORTANT
 You will receive a survey from General Motors shortly. Your Complete Satisfaction is our goal. If for any reason you cannot give us a "Completely Satisfied" please contact Customer Relations Consultant before mailing survey.
 Gillespie Auto Group
 (773) 470-2729

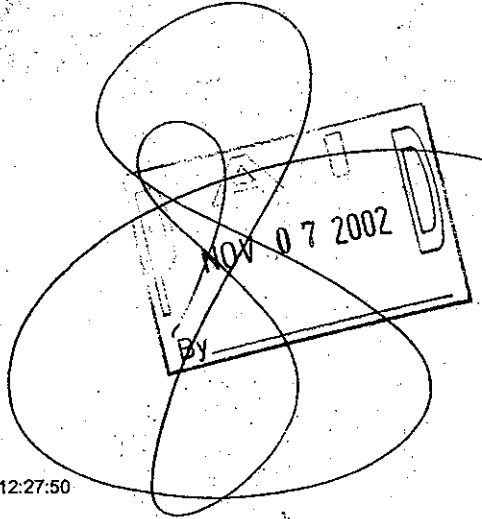

GM SERVICE CENTER

6603-33 So. Western Ave.
Chicago, Illinois 60636
773 434-8200
Fax 773 470-2790



www.gillespieautogroup.com

DISCLAIMER OF WARRANTIES - Any warranties on the products sold hereby are those made by the manufacturer. The Selling Dealer hereby expressly disclaims all warranties, either express or implied, including any implied warranty of merchantability or fitness for a particular purpose, and the Selling Dealer neither assumes nor authorizes any other person to assume for it any liability in connection with the sale of this part(s) and/or service. Manufacturer's warranty 12 months/12,000 miles parts and labor. Buyer shall not be entitled to recover from the Selling Dealer any consequential damages, damages to property, damages for loss of use, loss of time, loss of profit or income, or any other incidental damages.

CUSTOMER NO. [REDACTED]	ADVISOR JEREMIAH MITRE	6907	TAG NO. [REDACTED]	INVOICE DATE 11/07/02	INVOICE NO. PNCS49875
[REDACTED]	LABOR RATE 105.00	LICENSE NO.	MILEAGE 17,587	COLOR NAVY BLUE M	STOCK NO.
CHICAGO, IL	YEAR / MAKE / MODEL 01/PONTIAC/GRAND PRIX/2 DOOR COUPE			DELIVERY DATE 07/30/01	DELIVERY MILES 6,011
	VEHICLE I.D. NO. 1 G 2 W R 1 2 1 6 1 F			SELLING DEALER NO.	PRODUCTION DATE
	F.T.E. NO.	P.O. NO.	R.O. DATE 11/07/02		

LABOR & PARTS
J# 01PNZ EXTERIOR TRIM UNITS: 0.30 TECH(S): 620 WARRANTY
 DOOR MOLDING FALLING OFF, INSTALL SOP MOLDINGS.
 REPLACED DRIVER DOOR MOLDING.

PARTS	QTY	FP-NUMBER	DESCRIPTION	UNIT PRICE	WARRANTY
JOB # 1	1	12455145	MLDG-F/SD 12.112		
				JOB # 1 TOTAL PARTS	0.00
				JOB # 1 TOTAL LABOR & PARTS	0.00

SUBLET PO# 18125 VEND INV# 11/07/02 DESCRIPTION PAINT MLDG
 TOTAL - SUBLET WARRANTY 0.00

COMMENTS: WAITER

TOTALS

 * NEXT RECOMMENDED SERVICE: *
 * 12/07/2006 / 18333 MI 01PNZZRT TIRE ROTATE *

*****	TOTAL LABOR....	0.00
*	TOTAL PARTS....	0.00
*	TOTAL SUBLET...	0.00
*	TOTAL G.O.G....	0.00
*	TOTAL MISC CHG.	0.00
*	TOTAL MISC DISC	0.00
*	TOTAL TAX.....	0.00
*****	TOTAL INVOICE \$	0.00

THANK YOU FOR YOUR BUSINESS!!

CUSTOMER SIGNATURE _____
 ***** DUPLICATE INVOICE *****



CHEVROLET



PONTIAC

GMC



BUICK

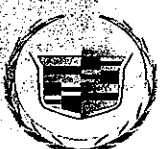

Cadillac



Goodwrench



GM SERVICE CENTER

6603-33 So. Western Ave.
 Chicago, Illinois 60636
 773 434-8200
 Fax 773 434-5906
 www.gillespieautogroup.com



DISCLAIMER OF WARRANTIES - Any warranties on the products sold hereby are those made by the manufacturer. The Selling Dealer hereby expressly disclaims all warranties, either express or implied, including any implied warranty of merchantability or fitness for a particular purpose, and the Selling Dealer neither assumes nor authorizes any other person to assume for it any liability in connection with the sale of this part(s) and/or service. Manufacturer's warranty 12 months/12,000 miles parts and labor. Buyer shall not be entitled to recover from the Selling Dealer any consequential damages, damages to property, damages for loss of use, loss of time, loss of profit or income, or any other incidental damages.

CUSTOMER NO. [REDACTED]	ADVISOR JEREMIAH MITRE	TAG NO. 6907	INVOICE DATE 08/11/03	INVOICE NO. PNC564478
[REDACTED] CHICAGO, IL [REDACTED]	LABOR RATE 85.00	LICENSE NO.	MILEAGE 26,055	COLOR NAVY BLUE M
	YEAR / MAKE / MODEL 01/PONTIAC/GRAND PRIX/2DR CPE GTP		DELIVERY DATE 07/30/01	STOCK NO. 5360
	VEHICLE I.D. NO. 1 G 2 W R 1 2 1 6 1 F		SELLING DEALER NO.	DELIVERY MILES 6,011
	F.T.E. NO.	P.O. NO.	R.O. DATE 08/11/03	PRODUCTION DATE
RESIDENCE PHONE [REDACTED]	BUSINESS PHONE [REDACTED]	COMMENTS		

TOTALS

*****	TOTAL LABOR....	0.00
*****	TOTAL PARTS....	0.00
* [] CASH [] CHECK CK NO. [] *	TOTAL SUBLET....	0.00
* [] VISA [] MASTERCARD [] DISCOVER *	TOTAL G.O.G....	0.00
* [] AMER XPRESS [] OTHER [] CHARGE *	TOTAL MISC CHG.	0.00
*****	TOTAL MISC DISC	0.00
	TOTAL TAX.....	0.00
	TOTAL INVOICE \$	0.00

THANK YOU FOR YOUR BUSINESS!!
 [REDACTED]

Stamp: PAID
 Signature: [Handwritten Signature]



GM SERVICE CENTER

6603-33 So. Western Ave.
Chicago, Illinois 60636
773 434-8200
Fax 773 434-5906



www.gillespieautogroup.com

DISCLAIMER OF WARRANTIES - Any warranties on the products sold hereby are those made by the manufacturer. The Selling Dealer hereby expressly disclaims all warranties, either express or implied, including any implied warranty of merchantability or fitness for a particular purpose, and the Selling Dealer neither assumes nor authorizes any other person to assume for it any liability in connection with the sale of this part(s) and/or service. Manufacturer's warranty 12 months/12,000 miles parts and labor. Buyer shall not be entitled to recover from the Selling Dealer any consequential damages, damages to property, damages for loss of use, loss of time, loss of profit or income, or any other incidental damages.

CUSTOMER NO.	ADVISOR	TAG NO.	INVOICE DATE	INVOICE NO.
[REDACTED]	JEREMIAH MITRE	6907	08/11/03	PNC564478
	LABOR RATE	LICENSE NO.	COLOR	STOCK NO.
	85.00		NAVY BLUE M	5360
	YEAR / MAKE / MODEL	MILEAGE	DELIVERY DATE	DELIVERY MILES
CHICAGO, IL	01/PONTIAC/GRAND PRIX/2DR CPE GTP	26,055	07/30/01	6,011
	VEHICLE I.D. NO.	SELLING DEALER NO.	PRODUCTION DATE	
	1 G 2 W R 1 2 1 6 1 F			
	F.T.E. NO.	P.O. NO.	R.O. DATE	
			08/11/03	
RESIDENCE PHONE	BUSINESS PHONE	COMMENTS		
[REDACTED]	[REDACTED]			

LABOR & PARTS
 J# 1 21PNZ01 A/C CONCERN UNITS: 0.80 TECH(S):620 WARRANTY
 CUSTOMER STATES THAT WHEN A/C IS TURN ON A FOUL ODOR COMES
 OUT OF VENTS.
 ?
 DIAGNOSED AND PERFORMED BULLETIN #99-01-39-004A
 INSTALLED AIR CONDITIONING ODOR KIT.

PARTS	QTY	FP-NUMBER	DESCRIPTION	UNIT PRICE	WARRANTY
NOB # 1	1	12346391	COOLING C 8.800		WARRANTY
NOB # 1	1	12497910	MODULE 9.275		WARRANTY
				JOB # 1 TOTAL PARTS	0.00
				JOB # 1 TOTAL LABOR & PARTS	0.00

J# 2 21PNZ AIR CONDITIONING UNITS: 0.30 TECH(S):620 WARRANTY
 CUSTOMER STATES THAT A/C IS NOT COLD ENOUGH.
 CANNOT DUPLICATE CUSTOMER CONCERN AT THIS TIME.

PARTS	QTY	FP-NUMBER	DESCRIPTION	UNIT PRICE	WARRANTY
				JOB # 2 TOTAL PARTS	0.00
				JOB # 2 TOTAL LABOR & PARTS	0.00

J# 3 85PNZ ACCESSORIES UNITS: 0.60 TECH(S):620 WARRANTY
 CUSTOMER STATES THAT DISPLAY SCREEN ON RADIO CAN NOT BE READ
 ALSO WHEN CD ARE PLAYING CD'S SKIP.
 DIAGNOSED AND REMOVED RADIO AND SENT OUT FOR REPAIRS.

PARTS	QTY	FP-NUMBER	DESCRIPTION	UNIT PRICE	WARRANTY
				JOB # 3 TOTAL PARTS	0.00
				JOB # 3 TOTAL LABOR & PARTS	0.00

J# 4 70PNZ03 RENTAL UNITS: TECH(S):999 WARRANTY
 RENTAL
 RENTAL

PARTS	QTY	FP-NUMBER	DESCRIPTION	UNIT PRICE	WARRANTY
				JOB # 4 TOTAL PARTS	0.00
				JOB # 4 TOTAL LABOR & PARTS	0.00

SUBLET - PO# - VEND INV# - INV. DATE - DESCRIPTION - WARRANTY
 JOB # 4 22453 08/11/03 RENTAL
 TOTAL - SUBLET 0.00

COMMENTS
 CALL

A/C - Odor Emission in Hot Weather

File In Section: 01 - HVAC

Bulletin No.: 99-01-39-004A

Date: May, 2001

TECHNICAL

Subject:
Air Conditioning Odor (Install Kit)

Models:
1993-2002 Passenger Cars
1993-2002 Light & Medium Duty Trucks

This bulletin is being revised to update the model years, service procedure, parts information and to add the GEO and Medium Duty models. Please discard Corporate Bulletin Number 99-01-39-004 (Section 01 - HVAC).

Condition

Some customers may comment on odors emitted from the air conditioning system, primarily at start-up in hot humid climates.

Cause

This odor may be the result of microbial growth on the evaporator core. When the blower motor fan is turned on, the microbial growth may release an unpleasant, musty odor into the passenger compartment. There are several other possible sources of a musty odor in a vehicle. A common source is a water leak. Follow the Service Manual procedure for identifying and correcting water leaks if other odor sources are found. The procedure contained in this bulletin is only applicable if the source of the odor has already been determined to be the HVAC module.

Correction

To remove odors of this type, it is necessary to eliminate the microbial growth and prevent its reoccurrence. To accomplish this, the following steps must be completed:

1. Apply evaporator core Cooling Coil Coating (Aerosol 6 oz), P/N 12377951 (AC Delco(R) 15-102) (in Canada, use P/N 10953503) or Cooling Coil Coating Kit with Extension Nozzle, P/N 12346391 (AC Delco(R) 10-120).

Refills are available for the Cooling Coil Coating Kit with Extension Nozzle, P/N 12346391 (AC Delco(R) 10-120). Refer to the chart below.

2. Install the Electronic Evaporator Dryer, P/N 12497910 (AC Delco(R) 15-5876).

Important : The Cooling Coil Coatings listed above are the only GM approved products for the disinfection and long-term control of evaporator microbial growth. The Cooling Coil Coating will disinfect the evaporator core and help inhibit the growth of future mold and mildew.

The Electronic Evaporator Dryer will activate when the ambient temperature near the module is above 16°C (60°F) when the vehicle is started up. Approximately 30 minutes after the vehicle has been turned off, the blower will activate for 10 seconds every 10 minutes for 2 hours unless the vehicle is restarted. If a restart occurs, the Electronic Evaporator Dryer module will reset automatically. This on/off blower activation will dry the evaporator core and case reducing the chance of reoccurring A/C odor. The Electronic Evaporator Dryer is self fused and has a battery rundown protection feature that inactivates the dryer if voltage drops below 12.5 volts.

Service Procedure

1. Visually inspect the air conditioning evaporator drain hose for obstructions and/or working condition.
2. The cooling coil coating fluid must be applied to a dry evaporator core. Apply coil coating fluid as described in the instructions supplied with the kit. In some instances, the blower motor resistor can be removed for this spraying operation. If used, the opening can be taped over and the nozzle inserted through a hole in the tape. The kit instructions identify a drilling procedure to apply the coating fluid. When using this type of procedure, care must be taken to avoid evaporator damage and any holes must be properly sealed. Some coating fluid may overflow from the drain hose.

Important : When installing the Electric Evaporator Module, you MUST use the included electrical splice connectors to ensure a splice.

3. Complete detailed installation instructions and wire connectors are supplied with the Electronic Evaporator Dryer. The ground wire should be attached to a body ground source. If any other wire splicing procedures are needed, follow the wire repair procedures in the Electrical sub-section of Body & Accessories in the appropriate Service Manual. If required, the evaporator dryer can be installed underhood away from extreme heat conditions (i.e. exhaust manifolds) and/or water splash areas. In all cases, the evaporator dryer module must be secured with a Velcro(R) strip (not included in the kit), or you may use the integral hooks to utilize tie straps. Using a Velcro(R) strip is preferred as the use of the integral hooks may cause rattles.

4. When the installation procedure is complete and power is supplied, the module will self-test. Thirty seconds after power is supplied, the high blower speed will be activated 3 times (for 2 seconds per cycle). When the test has run, install the Electronic Evaporator Dryer label on the blower motor case in a visible area.

Part Number	Description
12377951 (AC Delco® 15-102)	Cooling Coil Coating (Aerosol 6 oz)
12346391 (AC Delco® 10-120)	Cooling Coil Coating Kit w/Extension Nozzle
12346390 (AC Delco® 10-121)	Refill for Cooling Coil Coating Kit
12497910 (AC Delco® 15-5876)	Electronic Evaporator Dryer Module Kit

Parts Information

Parts are expected to be available from GMSPO, 6/4/01.

Warranty Information

Labor Operation	Description	Labor Time
D3316	Apply Cooling Coil Coating/Install Electronic Evaporator Dryer	0.8 hr

For vehicles repaired under warranty, use the table.



GM SERVICE CENTER

6603-33 So. Western Ave.
 Chicago, Illinois 60636
 773 434-8200
 Fax 773 470-2790
 www.gillespieautogroup.com



DISCLAIMER OF WARRANTIES - Any warranties on the products sold hereby are those made by the manufacturer. The Selling Dealer hereby expressly disclaims all warranties, either express or implied, including any implied warranty of merchantability or fitness for a particular purpose, and the Selling Dealer neither assumes nor authorizes any other person to assume for it any liability in connection with the sale of this part(s) and/or service. Manufacturer's warranty 12 months/12,000 miles parts and labor. Buyer shall not be entitled to recover from the Selling Dealer any consequential damages, damages to property, damages to loss of use, loss of time, loss of profit or income, or any other incidental damages.

CUSTOMER NO.	ADVISOR JEREMIAH MITRE	6907	TAG NO.	INVOICE DATE 08/11/03	INVOICE NO. PNC564478
	LABOR RATE 105.00	LICENSE NO.	MILEAGE 26,055	COLOR NAVY BLUE M	STOCK NO.
CHICAGO, IL	YEAR / MAKE / MODEL 01/PONTIAC/GRAND PRIX/2 DOOR COUPE			DELIVERY DATE 07/30/01	DELIVERY MILES 6,011
	VEHICLE I.D. NO. 1 G 2 W R 1 2 1 6 1 F			SELLING DEALER NO.	PRODUCTION DATE
	F.T.E. NO.	P.O. NO.	P.O. DATE 08/11/03		
COMMENTS					

LABOR & PARTS
 #1 21PNZ01 A/C CONCERN UNITS: 0.80 TECH(S): 620 WARRANTY
 CUSTOMER STATES THAT WHEN A/C IS TURN ON A FOUL ODOR COMES OUT OF VENTS.
 ?
 DIAGNOSED AND PERFORMED BULLETIN #99-01-39-004A
 INSTALLED AIR CONDITIONING ODOR KIT.

PARTS	QTY	FP-NUMBER	DESCRIPTION	UNIT PRICE	WARRANTY
JOB # 1	1	12346391	COOLING C 8.800		WARRANTY
JOB # 1	1	12497910	MODULE 9.275		WARRANTY
JOB # 1 TOTAL PARTS				0.00	
JOB # 1 TOTAL LABOR & PARTS				0.00	

#2 21PNZ01 AIR CONDITIONING UNITS: 0.30 TECH(S): 620 WARRANTY
 CUSTOMER STATES THAT A/C IS NOT COLD ENOUGH.
 CANNOT DUPLICATE CUSTOMER CONCERN AT THIS TIME.

PARTS	QTY	FP-NUMBER	DESCRIPTION	UNIT PRICE	WARRANTY
JOB # 2 TOTAL PARTS				0.00	
JOB # 2 TOTAL LABOR & PARTS				0.00	

#3 85PNZ01 ACCESSORIES UNITS: 0.60 TECH(S): 620 WARRANTY
 CUSTOMER STATES THAT DISPLAY SCREEN ON RADIO CAN NOT BE READ
 ALSO WHEN CD ARE PLAYING CD'S SKIP.
 DIAGNOSED AND REMOVED RADIO AND SENT OUT FOR REPAIRS.

PARTS	QTY	FP-NUMBER	DESCRIPTION	UNIT PRICE	WARRANTY
JOB # 3 TOTAL PARTS				0.00	
JOB # 3 TOTAL LABOR & PARTS				0.00	

#4 70PNZ01 RENTAL UNITS: 0.00 TECH(S): 999 WARRANTY
 RENTAL
 RENTAL

PARTS	QTY	FP-NUMBER	DESCRIPTION	UNIT PRICE	WARRANTY
JOB # 4 TOTAL PARTS				0.00	
JOB # 4 TOTAL LABOR & PARTS				0.00	

SUBLET PO# VEND INV# INV DATE DESCRIPTION WARRANTY
 JOB # 4 22453 08/11/03 RENTAL 0.00
 TOTAL - SUBLET 0.00

COMMENTS
 CALL



Reynolds and Reynolds ERMNTS14E F. 090926 Q (03/06)



GM SERVICE CENTER

6603-33 So. Western Ave.
 Chicago, Illinois 60636
 773 434-8200
 Fax 773 470-2790
 www.gillespieautogroup.com



DISCLAIMER OF WARRANTIES - Any warranties on the products sold hereby are those made by the manufacturer. The Selling Dealer hereby expressly disclaims all warranties, either express or implied, including any implied warranty of merchantability or fitness for a particular purpose, and the Selling Dealer neither assumes nor authorizes any other person to assume for it any liability in connection with the sale of this part(s) and/or service. Manufacturer's warranty 12 months/12,000 miles parts and labor. Buyer shall not be entitled to recover from the Selling Dealer any consequential damages, damages to property, damages for loss of use, loss of time, loss of profit or income, or any other incidental damages.

CUSTOMER NO.	ADVISOR JEREMIAH MITRE	6907	TAG NO.	INVOICE DATE 08/11/03	INVOICE NO. PNC564478
	LABOR RATE 105.00	LICENSE NO.	MILEAGE 26,055	COLOR NAVY BLUE M	STOCK NO.
CHICAGO, IL	YEAR / MAKE / MODEL 01/PONTIAC/GRAND PRIX/2 DOOR COUPE			DELIVERY DATE 07/30/01	DELIVERY MILES 6,011
	VEHICLE I.D. NO. 1 G 2 W R 1 2 1 6 1 F			SELLING DEALER NO.	PRODUCTION DATE
	F.T.E. NO.	P.O. NO.	P.O. DATE 08/11/03		
COMMENTS					

TOTALS

 * NEXT RECOMMENDED SERVICE: *
 * 12/04/2006 / 26865 MI 01PNZZRT TIRE ROTATE *

 * TOTAL LABOR..... 0.00 *
 * TOTAL PARTS..... 0.00 *
 * TOTAL SUBLET... 0.00 *
 * TOTAL G.O.G.... 0.00 *
 * TOTAL MISC CHG. 0.00 *
 * TOTAL MISC DISC 0.00 *
 * TOTAL TAX..... 0.00 *

TOTAL INVOICE \$ 0.00

THANK YOU FOR YOUR BUSINESS!!

CUSTOMER SIGNATURE _____
 ***** DUPLICATE INVOICE *****



Reynolds and Reynolds EDWARDS14E FL609266 O (03/06)



GM SERVICE CENTER

6603-33 So. Western Ave.
 Chicago, Illinois 60636
 773 434-8200
 Fax 773 434-5906
 www.gillespieautogroup.com



DISCLAIMER OF WARRANTIES - Any warranties on the products sold hereby are those made by the manufacturer. The Selling Dealer hereby expressly disclaims all warranties, either express or implied, including any implied warranty of merchantability or fitness for a particular purpose, and the Selling Dealer neither assumes nor authorizes any other person to assume for it any liability in connection with the sale of this part(s) and/or service. Manufacturer's warranty - 2 months / 2,000 miles parts and labor. Buyer shall not be entitled to recover from the Selling Dealer any consequential damages, damages to property, damages for loss of use, loss of time, loss of profit or income, or any other incidental damages.

CUSTOMER NO. [REDACTED]	ADVISOR DEREMIAH MITRE	TAG NO. [REDACTED]	INVOICE DATE 08/22/03	INVOICE NO. PNCS65236
[REDACTED]	LABOR RATE 85.00	LICENSE NO. [REDACTED]	MILEAGE 26,355	COLOR NAVY BLUE M
CHICAGO, IL [REDACTED]	YEAR / MAKE / MODEL 01/PONTIAC/GRAND PRIX/2DR CPE GTP	DELIVERY DATE 07/30/01	STOCK NO. 5360	DELIVERY MILES 6,011
[REDACTED]	VEHICLE I.D. NO. 1 G 2 W R 1 2 1 6 1 F [REDACTED]	SELLING DEALER NO. [REDACTED]	PRODUCTION DATE	
[REDACTED]	F.T.E. NO. [REDACTED]	P.O. NO. [REDACTED]	R.O. DATE 08/22/03	
COMMENTS				

LABOR & PARTS
 # 1 85PNZ ACCESSORIES UNITS: 0.30 TECH(S):620 WARRANTY
 CD PLAYER SKIPS.
 INSTALL SOP CD PLAYER.
 REINSTALLED RADIO.

JOB # 1 TOTAL LABOR & PARTS 0.00

COMMENTS
 WAITER

TOTALS

*****	TOTAL LABOR....	0.00
*****	TOTAL PARTS....	0.00
* [] CASH [] CHECK CK NO. []	TOTAL SUBLET....	0.00
* [] VISA [] MASTERCARD [] DISCOVER	TOTAL G.O.G....	0.00
* [] AMER XPRESS [] OTHER [] CHARGE	TOTAL MISC CHG.	0.00
*****	TOTAL MISC DISC	0.00
	TOTAL TAX.....	0.00
	TOTAL INVOICE \$	0.00

THANK YOU FOR YOUR BUSINESS!!

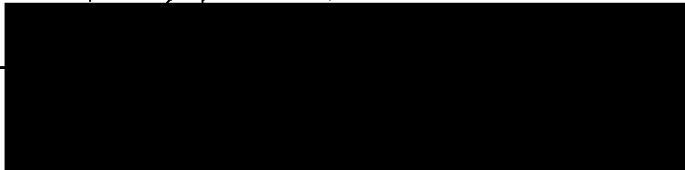

IMPORTANT
 You will receive a survey from General Motors shortly. Your Complete Satisfaction is our goal. If for any reason you cannot give us a "Completely Satisfied" please contact Customer Relations Consultant before mailing survey.
 Gillespie Auto Group
 (773) 470-2123

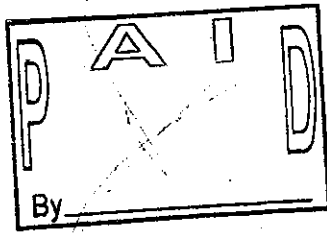



Thank You

Chicagoland's Original Superstore

CUSTOMER NO. [REDACTED]	ADVISOR MICHAEL COLLINS 474	TAG # [REDACTED]	INVOICE DATE 11/15/04	INVOICE NO. 0005200900
[REDACTED]	LABOR RATE	LICENSE NO.	MILEAGE IN 3/023	COLOR BLUE/
[REDACTED]	YEAR / MAKE / MODEL 01/FORD/GRAN PRIX		DELIVERY DATE 07/30/01	STOCK NO.
[REDACTED]	VEHICLE ID. NO. 1G2WR12151F [REDACTED]		SELLING DEALER NO.	DELIVERY MILES
CHICAGO, IL [REDACTED]	E.T.E. NO.		P.O. NO.	R.O. DATE 11/01/04
RESIDENCE PHONE [REDACTED]	BUSINESS PHONE [REDACTED]		MILEAGE OUT	

JOB # 4 TOTAL LABOR & PARTS

SUBLET	PO#	PLND	INVR	INV. DATE	DESCRIPTION	
JOB # 3	101576			11/15/04	RENTAL	0.00
JOB # 3	101576			11/15/04	RENTAL	0.00
TOTAL - SUBLET						0.00
G.O.G. & SUPPLIES						
JOB # 1	25000					0.00
TOTAL - GOG						0.00

ESTIMATE
CUSTOMER HEREBY ACKNOWLEDGES RECEIVING ORIGINAL ESTIMATE OF \$0.00 (+TAX)
COMMENTS
GMPP O DEDUCTIBLE
CHARGE RENTAL INTERNAL WAITING FOR PARTS AND OVER WEEKEND REPAIRS
GMPP OKD 8 DAYS RENTAL

CHARGE <input type="checkbox"/> VISA <input type="checkbox"/> MASTER <input type="checkbox"/> AMEX <input type="checkbox"/>	TOTAL LABOR	0.00
DISCOVER <input type="checkbox"/> CARTE BLANCHE <input type="checkbox"/> DINERS <input type="checkbox"/>	TOTAL PARTS	0.00
CHECK# <input type="checkbox"/> CASH <input type="checkbox"/> CAR CARD ONE <input type="checkbox"/>	TOTAL SUBLET	0.00
CHICAGO LICENCE NUMBERS 00550038 AND 00550032	TOTAL G.O.G.	0.00
***** SERVICE DEPARTMENT HOURS *****	TOTAL MISC CHG.	0.00
MONDAY THROUGH FRIDAY 7:00AM TO 6:00PM	TOTAL MISC DISC	0.00
SATURDAY 8:00AM TO 12:00 FOR DROP OFF AND PICK UP	TOTAL TAX	0.00
PAY ONLY \$12.95 FOR AN OIL CHANGE WHEN YOU JOIN THE "Z" FRANK VIP CLUB. ASK FOR DETAILS	TOTAL INVOICE \$	0.00

X *Thank You For Choosing Z Frank!*

PLEASE SEE REVERSE SIDE FOR ADDITIONAL WARRANTY INFORMATION

YOUR VEHICLE. FOR FUTURE SERVICE.
PLEASE CALL (773) 508-4110 FOR A RESER-
VATION.



Service
Parts
Sales
Leasing

Parts Line Direct (773) 508-4117
6060/ 6123 N. Western Ave.
CHICAGO, IL 60659

Thank You

Chicagoland's Original Superstore

CUSTOMER NO.	ADVISOR MICHAEL COLLINS 474	TAG #	INVOICE DATE 11/22/04	INVOICE NO. CVC530686
	LABOR RATE	LICENSE NO.	MILEAGE IN 37191	COLOR SL GR/
	YEAR / MAKE / MODEL 01/PONTIAC/GRAN PRIX		DELIVERY DATE 07/30/01	STOCK NO.
	VEHICLE ID. NO. 1 G 2 W R 1 2 1 6 1 F		SELLING DEALER NO.	DELIVERY MILES
CHICAGO, IL	F.T.E. NO.	P.O. NO.	R.O. DATE 11/22/04	PRODUCTION DATE
RESIDENCE PHONE	BUSINESS PHONE			MILEAGE OUT

LABOR & PARTS
JOB # 1 14CVZ WHEELS & TIRES MISC TECH(S):790 WARRANTY
CUSTOMER STATES THAT THERE IS A CLICKING NOISE FROM THE LEFT
FRONT CHECK AND ADVISE
LEFT FRONT HUB BEARING NOISY
REPLACE LEFT FRONT HUB BEARING ASSEMBLY

PARTS	QTY	FP-NUMBER	DESCRIPTION	UNIT PRICE	WARRANTY
JOB # 1	1	12429204	HUB KIT 6.307 R		
				JOB # 1 TOTAL PARTS	0.00
				JOB # 1 TOTAL LABOR & PARTS	0.00

J# 2+36CVZ STEERING TECH(S):790 WARRANTY
DURING INSPECTION FOUND THE LEFT FRONT CV OUTER BOOT LEAKING
CV BOOT LEAKING
REPLACE LEFT SIDE OUTER CV BOOT

PARTS	QTY	FP-NUMBER	DESCRIPTION	UNIT PRICE	WARRANTY
JOB # 2	1	26044383	BOOT KIT, 6.061 *		
				JOB # 2 TOTAL PARTS	0.00
				JOB # 2 TOTAL LABOR & PARTS	0.00

COMMENTS
790 TECH SERVICE RETURN
ANTON AT MRP ORU REPAIRS
O BED

TOTALS

CHARGE <input type="checkbox"/> VISA <input type="checkbox"/> MAFER <input type="checkbox"/> AMEX <input type="checkbox"/>	TOTAL LABOR...	0.00
DISCOVER <input type="checkbox"/> CARTE BLANC <input type="checkbox"/> OTHERS <input type="checkbox"/>	TOTAL PARTS...	0.00
CHECK# <input type="checkbox"/> CASH <input type="checkbox"/> CAR CARE ONE <input type="checkbox"/>	TOTAL SUBLET...	0.00
CHICAGO LICENSE NUMBERS 005350-0 AND 0053582	TOTAL S.O.C...	0.00
*****	TOTAL MISC CHG...	0.00
SERVICE DEPARTMENT HOURS	TOTAL WISC DIS...	0.00
MONDAY THROUGH FRIDAY 7:00AM TO 6:00PM	TOTAL TAX.....	0.00
SAURDAY 8:00AM TO 12:00 FOR DROP OFF AND PICK UP	TOTAL INVOICE \$	0.00

PAY ONLY \$12.95 FOR AN OIL CHANGE WHEN YOU
JOIN THE "Z" FRANK VIP CLUB. ASK FOR DETAILS

CUSTOMER SIGNATURE

X

Thank You For Choosing Z Frank!

PLEASE SEE REVERSE SIDE FOR ADDITIONAL WARRANTY INFORMATION



World's Largest Chevrolet Dealer

6060 North Western Avenue • Chicago, IL 60659
Telephone: 773/465-2000

THANK YOU

...for allowing us to take care of your automotive needs. We appreciate you and we are here to assist you anytime you may need maintenance or advice about service needs. With our full endorsement, you may soon receive a survey from General Motors. The primary purpose of this survey is to participate in a grade scale for our dealership.

Completely Satisfied 75% - 100% = A-B-C	Very Satisfied 50% - 74% = D-F	Satisfied 49% - 25% = F	Somewhat Satisfied 24% - 1% = F	Not At All Satisfied 0% = F
---	--------------------------------------	-------------------------------	---------------------------------------	-----------------------------------

Please note that any answer less than "COMPLETELY SATISFIED" equates to a failing grade of "D" for us. I sincerely hope that your experience with us warrants a "C" or better grade. We would very much appreciate as many "COMPLETELY SATISFIED" responses as possible on the survey.

If we need improvement in any area, I would personally be honored to hear from you. Feel free to call me or stop by anytime to speak with me. I am here because of you; I am here for you. Once again, my heartfelt thanks for the privilege of taking care of your automotive needs.

Michael J Ammer
Fixed Operations Director

24/7/365 WE'LL BE THERE

YOUR VEHICLE. FOR FUTURE MAINTENANCE,
PLEASE CALL (773) 508-4110 FOR A RESER-
VATION.



Service
Parts
Sales
Leasing

Parts Line Direct (773) 508-4117
6060/ 6123 N. Western Ave.
CHICAGO, IL 60659

Thank You

Chicagoland's Original Superstore

CUSTOMER NO. [REDACTED]	ADVISOR MICHAEL COLLINS 474	TAG # [REDACTED]	INVOICE DATE 08/02/05	INVOICE NO. CVC5218071
[REDACTED]	LABOR RATE	LICENSE NO.	MILEAGE IN 49680	COLOR BLUE/
[REDACTED]	YEAR / MAKE / MODEL 01/PONTIAC/GRAN PRIX	DELIVERY DATE 07/30/01	DELIVERY MILES	STOCK NO.
[REDACTED]	VEHICLE ID. NO. 1G2WR12161F [REDACTED]	SELLING DEALER NO.	PRODUCTION DATE	
CHICAGO, IL [REDACTED]	F.T.E. NO.	P.O. NO.	R.O. DATE 07/29/05	
RESIDENCE PHONE [REDACTED]	BUSINESS PHONE [REDACTED]			MILEAGE OUT

LABOR & PARTS
 J# 1 31CVZ BODY ELECTRICAL TECH(S):953 WARRANTY
 CUSTOMER STATES THAT THE SECURITY LITE IS ON AND THE
 KEY IS HARD TO GET IN THE IGNITION
 IGNITION CYLINDER BINDING
 REPLACE IGNITION CYLINDER AND CODE

PARTS	QTY	FP-NUMBER	DESCRIPTION	UNIT PRICE	WARRANTY
JOB # 1	1	12457103	CYLINDER 2.188		
				JOB # 1 TOTAL PARTS	0.00
				JOB # 1 TOTAL LABOR & PARTS	0.00

J# 2 19CVZB GMPP RENTAL TECH(S):474 WARRANTY
 GMPP RENTAL
 REASON FOR RENTAL
 RENTAL

PARTS	QTY	FP-NUMBER	DESCRIPTION	UNIT PRICE	WARRANTY
				JOB # 2 TOTAL PARTS	0.00
				JOB # 2 TOTAL LABOR & PARTS	0.00

J# 3+31CVZ1 BODY ELECTRICAL TECH(S):953 WARRANTY
 DURING INSPECTION FOUND MULTIPLE CONCERNS FOUND THE
 KEY WOULDNT COME OUT OF IGNITION
 INSPECT AND FOUND BROKEN WIRE CIRCUIT 1020 PINK WIRE
 AT THE SHIFT INTERLOCK
 REPAIR PINK WIRE AT CIRCUIT 1020

PARTS	QTY	FP-NUMBER	DESCRIPTION	UNIT PRICE	WARRANTY
				JOB # 3 TOTAL PARTS	0.00
				JOB # 3 TOTAL LABOR & PARTS	0.00

SUBLET	PDH	VEND INV#	INV.DATE	DESCRIPTION	WARRANTY
JOB # 2	107413	22222	08/02/05	RENTAL	
TOTAL - SUBLET					0.00

COMMENTS:
 RICK AT GMPP OKD REPAIRS AND 4 DAY RENTAL
 LINE 1 PARTS WARRANTY HISTORY ATTACHED
 CAR BOUGHT IN FRIDAY NOT READY TILL TUES
 RICK AT GMPP OKD 4 DAYS RENTAL

Goodwrench

Thank You For Choosing Z Frank!

PLEASE SEE REVERSE SIDE FOR ADDITIONAL WARRANTY INFORMATION
 CONTINUED ON NEXT PAGE

YOUR VEHICLE. FOR FUTURE MAINTENANCE.
PLEASE CALL (773) 508-4110 FOR A RESER-
VATION.



Parts
Sales
Leasing

Parts Line Direct (773) 508-4117
6060/ 6123 N. Western Ave.
CHICAGO, IL 60659

Thank You

Chicagoland's Original Superstore

CUSTOMER NO. [REDACTED]	ADVISOR MICHAEL COLLINS 474	TAG # [REDACTED]	INVOICE DATE 08/02/05	INVOICE NO. CVCS218071
[REDACTED]	LABOR RATE	LICENSE NO.	MILEAGE IN 49680	COLOR BLUE/
[REDACTED]	YEAR / MAKE / MODEL 01/PONTIAC/GRAN PRIX		DELIVERY DATE 07/30/01	DELIVERY MILES
[REDACTED]	VEHICLE ID. NO. 1G2WR12161F		SELLING DEALER NO.	PRODUCTION DATE
CHICAGO, IL [REDACTED]	F.T.E. NO.	P.O. NO.	R.O. DATE 07/29/05	
RESIDENCE PHONE [REDACTED]	BUSINESS PHONE [REDACTED]			MILEAGE OUT

TOTALS-----		
CHARGE [] VISA [] MASTER [] AMEX []	TOTAL LABOR....	0.00
DISCOVER [] CARTE BLANCE [] DINERS []	TOTAL PARTS....	0.00
CHECK# [] CASH [] CAR CARE ONE []	TOTAL SUBLET....	0.00
CHICAGO LICENCE NUMBERS 00535038 AND 00535852	TOTAL G.O.G....	0.00
*****	TOTAL MISC CHG.	0.00
SERVICE DEPARTMENT HOURS	TOTAL MISC DISC	0.00
MONDAY THROUGH FRIDAY 7:00AM TO 6:00PM	TOTAL TAX.....	0.00
SATURDAY 8:00AM TO 12:00 FOR DROP OFF AND PICK UP	TOTAL INVOICE \$	0.00

PAY ONLY \$12.95 FOR AN OIL CHANGE WHEN YOU
JOIN THE "Z" FRANK VIP CLUB. ASK FOR DETAILS

CUSTOMER SIGNATURE

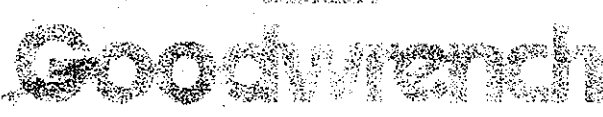

Thank You For Choosing Z Frank!

PLEASE SEE REVERSE SIDE FOR ADDITIONAL WARRANTY INFORMATION
[END OF INVOICE]



Thank You

Chicagoland's Original Superstore

CUSTOMER NO. [REDACTED]	ADVISOR MICHAEL COLLINS 474	TAG # [REDACTED]	INVOICE DATE 01/20/06	INVOICE NO. CVC0225865
[REDACTED]	LABOR RATE	LICENSE NO.	MILEAGE IN 55892	COLOR BLUE/
[REDACTED]	YEAR / MAKE / MODEL 01/PONTIAC/GRAN PRIX		DELIVERY DATE 07/30/01	DELIVERY MILES
[REDACTED]	VEHICLE ID. NO. 1G2WR12161F [REDACTED]		SELLING DEALER NO.	PRODUCTION DATE
CHICAGO, IL [REDACTED]	F.T.E. NO.	P.O. NO.	R.O. DATE 01/18/06	
RESIDENCE PHONE [REDACTED]	BUSINESS PHONE [REDACTED]			MILEAGE OUT

LABOR & PARTS
JH 1 33CVZ
BRAKE REPAIRS TECH(S):702
CUSTOMER STATES THAT THE PARKING BRAKE CABLE IS LOCKED
INTO PLACE, INSPECT AND ADVISE
PARKING BRAKE CABLE BINDING
REPLACE THE RT REAR PARKING BRAKE CABLE

WARRANTY

PARTS	QTY	FP NUMBER	DESCRIPTION	UNIT PRICE
				JOB # 1 TOTAL PARTS 0.00
				JOB # 1 TOTAL LABOR & PARTS 0.00

JH 2 36CVZ
STEERING TECH(S):702
CUSTOMER STATES THAT WHEN TURNING THE STEERING WHEEL THERE
IS A WHINNING NOISE, SOUNDS LIKE POWER STEERING NOISE
BOTH POWER STEERING HOSES LEAKING
REPLACE THE POWER STEERING PRESSURTE AND RETURN LINES

WARRANTY

PARTS	QTY	FP NUMBER	DESCRIPTION	UNIT PRICE
JOB # 2	1	15297496	CABLE 4.779	
JOB # 2	1	89020661	FLUID 8.800	
JOB # 2	1	26064183	HOSE 6.670	
JOB # 2	1	88997535	HOSE 6.671	
JOB # 2	2	744245	CLAMP 8.948	
				JOB # 2 TOTAL PARTS 0.00
				JOB # 2 TOTAL LABOR & PARTS 0.00

WARRANTY
WARRANTY
WARRANTY
WARRANTY
WARRANTY

JH 3 28CVZ
ENGINE MECHANICAL TECH(S):702
REPLACE THE SUPER CHARGER FLUID ADVISE ON COST BEFORE
CHANGING THE FLUID
REPLACED SUPER CHARGER FLUID

25.00

PARTS	QTY	FP NUMBER	DESCRIPTION	UNIT PRICE
JOB # 3	1	12345982	OIL-SUPER 8.800	6.78
				JOB # 3 TOTAL PARTS 6.78
				JOB # 3 TOTAL LABOR & PARTS 31.78

JH 4 24CVZ
HEAT AND A C TECH(S):702
CUSTOMER STATES THAT THE FAN IS INOP ON LOW SPEEDS
RESISTOR SHORTED
REPLACE THE BLOWER MOTOR RESISTOR

WARRANTY

PARTS	QTY	FP NUMBER	DESCRIPTION	UNIT PRICE
JOB # 4	1	89018643	RESISTOR 9.215	
				JOB # 4 TOTAL PARTS 0.00
				JOB # 4 TOTAL LABOR & PARTS 0.00

WARRANTY

JH 5 73CVZSHUTTLE
SHUTTLE DROP OFF TECH(S):474
COURTESY SHUTTLE Z7910 SIGNATURE
VEHICLE IN SHOP FOR REPAIRS
PROVIDED CUSTOMER WITH A RIDE

0.00

PARTS	QTY	FP NUMBER	DESCRIPTION	UNIT PRICE
				JOB # 5 TOTAL PARTS 0.00
				JOB # 5 TOTAL LABOR & PARTS 0.00

Thank You For Choosing Z Frank!

PLEASE SEE REVERSE SIDE FOR ADDITIONAL WARRANTY INFORMATION
[CONTINUED ON NEXT PAGE]

YOUR VEHICLE. FOR FUTURE MAINTENANCE,
PLEASE CALL (773) 508-4110 FOR A RESER-
VATION.



Parts
Sales
Leasing

Parts Line Direct (773) 508-4110
6060/ 6123 N. Western Ave.
CHICAGO, IL 60659

Thank You

Chicagoland's Original Superstore

CUSTOMER NO. [REDACTED]	ADVISOR MICHAEL COLLINS 474	TAG # [REDACTED]	INVOICE DATE 01/20/06	INVOICE NO. CVCS22586
[REDACTED]	LABOR RATE	LICENSE NO. *	MILEAGE IN 55892	COLOR BLUE/
	YEAR / MAKE / MODEL 01/PONTIAC/GRAN PRIX		DELIVERY DATE 07/30/01	DELIVERY MILES
	VEHICLE ID. NO. 1G2WR12161F [REDACTED]		SELLING DEALER NO.	PRODUCTION DATE
	F.T.E. NO.	PO. NO.	R.O. DATE 01/18/06	
RESIDENCE PHONE [REDACTED]	BUSINESS PHONE [REDACTED]			MILEAGE OUT

MISC	CODE	DESCRIPTION	CONTROL NO	
JOB # A	MISCSUPPL	MISC SUPPLIES		0.64
JOB # A	HAZW	ENVIRONMENTAL SERVICE FEE		2.99
TOTAL - MISC				3.63

ESTIMATE
CUSTOMER HEREBY ACKNOWLEDGES RECEIVING
ORIGINAL ESTIMATE OF \$97.43 (+TAX)

COMMENTS
GMPP ODED

TOTALS				
CHARGE []	VISA []	MASTER []	AMEX []	TOTAL LABOR.....
DISCOVER []	CARTE BLANCE []	DINERS []		TOTAL PARTS.....
CHECK# []	CASH []	CAR CARE ONE []		TOTAL SOBLET....
CHICAGO LICENCE NUMBERS 00535038 AND 00535037				TOTAL G.O.G.....
SERVICE DEPARTMENT HOURS				TOTAL MISC CHG.
MONDAY THROUGH FRIDAY 7:00AM TO 6:00PM				TOTAL MISC DISC
SATURDAY 8:00 TO 4:00PM				TOTAL TAX.....
NOW WE OFFER SERVICE ON SATURDAY				TOTAL INVOICE \$

03/16/35

CUSTOMER SIGNATURE

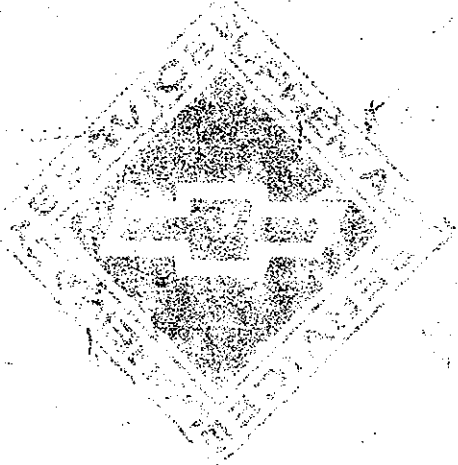

Goodwrench

X [REDACTED] *Thank You For Choosing Z Frank!*

PLEASE SEE REVERSE SIDE FOR ADDITIONAL WARRANTY INFORMATION

YOUR VEHICLE FOR FUTURE MAINTENANCE.
PLEASE CALL (773) 508-4110 FOR A RESER-
VATION.



Service Line Direct (773) 508-4110
Parts Line Direct (773) 508-4117
6060/ 6123 N. Western Ave.
CHICAGO, IL 60659

Thank You

Chicagoland's Original Superstore

CUSTOMER NO.	ADVISOR MICHAEL COLLINS	TAG #	INVOICE DATE 05/05/06	INVOICE NO. CVC5230702
	LABOR RATE	LICENSE NO.	COLOR BLUE	STOCK NO.
	YEAR/MAKE/MODEL 01/PONTIAC/GRAN PRIX	MILEAGE IN 38511	DELIVERY DATE 07/30/01	DELIVERY MILES
	VEHICLE ID. NO. 1G2UR12161F		SELLING DEALER NO.	PRODUCTION DATE
CHICAGO, IL	F.T.E. NO.	P.O. NO.	R.O. DATE 05/01/06	
RESIDENCE PHONE	BUSINESS PHONE			MILEAGE OUT

LABOR & PARTS
J# 1 36CVZ STEERING TECH(S):702 WARRANTY
CUSTOMER STATES THAT THERE IS POWER STEERING FLUID LEAKING FROM THE ENGINE AREA, HE HAD TO ADD FLUID. POWER STEERING PUMP SEAL LEAKING. REPLACE THE POWER STEERING FRONT PUMP SEAL.

PARTS	QTY	FP-NUMBER	DESCRIPTION	UNIT PRICE	
JOB # 1	1	26043126	SEAL-PUMP 6.617 R		WARRANTY
JOB # 1	1	89020661	FLUID 8.800		WARRANTY
JOB # 1	1	89020661	FLUID 8.800		WARRANTY
JOB # 1	1	J-41048			WARRANTY
JOB # 1	-1	J-41048			WARRANTY
				JOB # 1 TOTAL PARTS	0.00
				JOB # 1 TOTAL LABOR & PARTS	0.00

J# 2 28CVZLK OIL LEAK TECH(S):702 WARRANTY
CUSTOMER STATES THAT THERE IS OIL ELAKING FROM THE ENGINE AREA LOOKS LIKE FROM THE INTAKE????????????????? LOWER INTAKE LEAKING. REPLACE THE LOWER INTAKE MANIFOLD GASKET SET.

PARTS	QTY	FP-NUMBER	DESCRIPTION	UNIT PRICE	
JOB # 2	1	89017825	GSKT KIT 3.270		WARRANTY
JOB # 2	1	12346141	SEALANT-R 8.800		WARRANTY
JOB # 2	1	12346290	COOLANT 8.800		WARRANTY
JOB # 2	1	24503648	GSKT TH/B 3.336 R		WARRANTY
JOB # 2	1	24503911	GASKET 3.342 R		WARRANTY
JOB # 2	2	24501563	SEAL-THRO 3.337 R		WARRANTY
JOB # 2	1	24503423	PIPE ASM- 8.846		WARRANTY
				JOB # 2 TOTAL PARTS	0.00
				JOB # 2 TOTAL LABOR & PARTS	0.00

J# 3 13CVZTIRES 8/32 TECH(S):474 0.00
8/32 DR GREATER TREAD DEPTH

PARTS	QTY	FP-NUMBER	DESCRIPTION	UNIT PRICE	
				JOB # 3 TOTAL PARTS	0.00
				JOB # 3 TOTAL LABOR & PARTS	0.00

J# 4 15CVZODOR AIRCO FRESH DEODORIZ TECH(S):702 90.00
USING A PROVEN CLEANING PROCESS WE WILL REMOVE HARMFULL BACTERIA CONTAMINATES AND OTHER DERRIS FROM THE AIR CONDITIONING SYSTEM WHILE WE DISINFECT ALL THE AIR VENTS.

PARTS	QTY	FP-NUMBER	DESCRIPTION	UNIT PRICE	
JOB # 4	1	PKAIRCO	AIRCO DEODOR	39.95	39.95
JOB # 4	1	16101AIRCO	16101AIR AIRCO DEOD	****	****
				JOB # 4 TOTAL PARTS	39.95
				JOB # 4 TOTAL LABOR & PARTS	129.95

J# 5 73CVZSHUTTLE SHUTTLE DROP OFF TECH(S):474 WARRANTY
COURTESY SHUTTLE Z7910 SIGNATURE
VEHICLE IN SHOP FOR REPAIRS
PROVIDED CUSTOMER WITH A RIDE

X

Thank You For Choosing Z Frank!

YOUR VEHICLE FOR FUTURE MAINTENANCE.
PLEASE CALL (773) 508-4110 FOR A RESER-
VATION.



Parts
Sales
Leasing

Parts Line Direct (773) 508-4117
6060/ 6123 N. Western Ave.
CHICAGO, IL 60659

Thank You

Chicagoland's Original Superstore

CUSTOMER NO.	ADVISOR MICHAEL COLLINS 474	TAG #	INVOICE DATE 05/05/06	INVOICE NO. CVCS00702
	LABOR RATE	LICENSE NO.	MILEAGE IN 58511	COLOR BLUE
	YEAR/MAKE/MODEL 01/PONTIAC/GM PRX		DELIVERY DATE 07/30/01	STOCK NO.
	VEHICLE ID. NO. 1G2WR12131F		SELLING DEALER NO.	PRODUCTION DATE
	F.T.E. NO.		R.O. DATE 05/01/06	
CHICAGO, IL				MILEAGE OUT

PARTS	QTY	FP-NUMBER	DESCRIPTION	UNIT PRICE	WARRANTY
			JOB # 5 TOTAL PARTS	0.00	
			JOB # 5 TOTAL LABOR & PARTS	0.00	

J# 6+34CVZ SUSPENSION TECH(S):702 WARRANTY
DURING INSPECTION FOUND THE RACK N PINION LEAKING
RACK N PINION LEAKING
RT SIDE TIE ROD ALOS LOOSE
REPLACE THE RACK N PINION
REPLACE RT SIDE OUTER TIE ROD LOOSE, NO LABOR P ONLY
SET FROMNT TOE-SPECS ATTACHED

PARTS	QTY	FP-NUMBER	DESCRIPTION	UNIT PRICE	WARRANTY
JOB # 6	1	89020661	FLUID 8.800		WARRANTY
JOB # 6	1	89047698	ROD KIT 6.233		WARRANTY
JOB # 6	1	26079912	GEAR KIT 6.508		WARRANTY
JOB # 6	-1	26079912	CORE RETURN		WARRANTY
			JOB # 6 TOTAL PARTS	0.00	
			JOB # 6 TOTAL LABOR & PARTS	0.00	

J# 7+36CVZDIAG STEERING SYSTEM DIAG TECH(S):702 WARRANTY
DURING INSPECTION FOUND THE RT SIDE INNER CV BOOT
LEAKING, ADD ON 05/02/06
RT SIDE INNER CV BOOT LEAKING
REPLACE THE RT SIDE INNER CV BOOT

PARTS	QTY	FP-NUMBER	DESCRIPTION	UNIT PRICE	WARRANTY
JOB # 7	1	26073372	BOOT KIT 6.061		WARRANTY
			JOB # 7 TOTAL PARTS	0.00	
			JOB # 7 TOTAL LABOR & PARTS	0.00	

J# 8+34CVZDIAG SUSPENSION DIAG TECH(S):702 WARRANTY
DURING INSPECTION FOUND THE LEFT SIDE INNER CV BOOT
TORN
LEFT INNER CV BOOT TORN
REPLACE THE LEFT INNER CV BOOT

PARTS	QTY	FP-NUMBER	DESCRIPTION	UNIT PRICE	WARRANTY
JOB # 8	1	26073372	BOOT KIT 6.061		WARRANTY
			JOB # 8 TOTAL PARTS	0.00	
			JOB # 8 TOTAL LABOR & PARTS	0.00	

MISC	CODE	DESCRIPTION	CONTROL NO	
JOB # 5	SHR	SHUTTLE RIDE		5.00
			TOTAL - MISC	5.00

ESTIMATE
CUSTOMER HEREBY ACKNOWLEDGES RECEIVING
ORIGINAL ESTIMATE OF \$140.45 (+TAX)

COMMENTS
GMPP 0 DED

Thank You For Choosing Z Frank!

THANK YOU FOR THE OPPORTUNITY TO SERVICE YOUR VEHICLE. FOR FUTURE MAINTENANCE, PLEASE CALL (773) 508-4110 FOR A RESERVATION.



Service
Parts
Sales
Leasing

Service Line Direct (773) 508-4110
Parts Line Direct (773) 508-4117
6060/ 6123 N. Western Ave.
CHICAGO, IL 60659

Thank You

Chicagoland's Original Superstore

ADVISOR MICHAEL COLLINS 474		TAG #	INVOICE DATE 05/05/06	INVOICE NO. CVCS230702
LABOR RATE	LICENSE NO.	MILEAGE IN 58511	COLOR BLUE	STOCK NO.
YEAR / MAKE / MODEL 01/PONTIAC/GRAN PRIZ			DELIVERY DATE 07/30/01	DELIVERY MILES
VEHICLE ID. NO. 1G2WR12161F			SELLING DEALER NO.	PRODUCTION DATE
F.T.E. NO.		P.O. NO.	R.O. DATE 05/01/06	
BUSINESS PHONE			MILEAGE OUT	

TOTALS

CHARGE VISA MASTER AMEX
 DISCOVER CARTE BLANCA DINERS
 CHECK# CASH CAR CARE ONE

CHICAGO LICENCE NUMBERS 00535038 AND 00535852

SERVICE DEPARTMENT HOURS
 MONDAY THROUGH FRIDAY 7:00AM TO 6:00PM
 SATURDAY 8:00 TO 4:00PM

TOTAL LABOR.... 90.00
 TOTAL PARTS.... 39.99
 TOTAL SUBLET... 0.00
 TOTAL G.O.G.... 0.00
 TOTAL MISC CHG. 3.00
 TOTAL MISC DISC 0.00
 TOTAL TAX..... 3.60

 TOTAL INVOICE \$ 136.55

CUSTOMER SIGNATURE

Thank You For Choosing Z Frank!

PLEASE SEE REVERSE SIDE FOR ADDITIONAL WARRANTY INFORMATION

X



OUR VEHICLE FOR FUTURE MAINTENANCE.
PLEASE CALL (773) 508-4110 FOR A RESER-
VATION.



Service
Parts
Sales
Leasing

Service Line Direct (773) 508-4110
Parts Line Direct (773) 508-4117
6060/ 6123 N. Western Ave.
CHICAGO, IL 60659

Thank You

Chicagoland's Original Superstore

CUSTOMER NO. [REDACTED]	ADVISOR MICHAEL COLLINS 474	TAG # [REDACTED]	INVOICE DATE 08/08/06	INVOICE NO. CUPS235393
[REDACTED]	LABOR RATE	LICENSE NO.	MILEAGE IN 60818	COLOR BLUE/
[REDACTED]	YEAR / MAKE / MODEL 01/PONTIAC/GRAN PRIX		DELIVERY DATE 07/30/01	DELIVERY MILES
[REDACTED]	VEHICLE ID. NO. 1G2WR12161F		SELLING DEALER NO.	PRODUCTION DATE
CHICAGO, IL [REDACTED]	F.T.E. NO.	R.O. NO.	R.O. DATE 07/31/06	MILEAGE OUT
RESERVED PHONE [REDACTED]	BUSINESS PHONE [REDACTED]			

LABOR & PARTS
JH 1 28CVZ ENGINE MECHANICAL TECH(S):702 0.00
CUSTOMER STATES THAT THERE IS POSSIBLE OIL LEAKING FROM THE
LEFT SIDE OF THE MANFOLD GASKET, IS IT RESIDUE FROM
THE LAST REPAIR, ADVISE
NO CORRECTIONS, LEFT OVER RESIDUE

PARTS	QTY	FP-NUMBER	DESCRIPTION	UNIT PRICE
			JOB # 1 TOTAL PARTS	0.00
			JOB # 1 TOTAL LABOR & PARTS	0.00

JH 2 24CVZ HEAT AND A C TECH(S):702 199.97
CUSTOMER STATES THAT THE AC IS BLOWING WARM AIR
INSPECT AND ADVISE ON NEEDED REPAIRS
LOW ON R134 CHECK FOR LEAKS NONE FOUND
EVACUATE AND RECHARGE THE AC

PARTS	QTY	FP-NUMBER	DESCRIPTION	UNIT PRICE
JOB # 2	1	12356150	R134 REON 8.800	24.01
			JOB # 2 TOTAL PARTS	24.01
			JOB # 2 TOTAL LABOR & PARTS	223.98

MISC CODE DESCRIPTION CONTROL NO
JOB # A MISC SUPPL MISC SUPPLIES
TOTAL - MISC 3.98

ESTIMATE
CUSTOMER HEREBY ACKNOWLEDGES RECEIVING
ORIGINAL ESTIMATE OF \$0.00 (+TAX)
APPROVED REVISED ESTIMATE (# 1) OF \$264.00 (+TAX) ON 08/08/06 AT 03:36pm
BY ANDREW FINKO COMMENTS
WAITER ON OK FROM GMPF IF POICY IS STILL GOOD

TOTALS		
CHARGE <input type="checkbox"/> VISA <input type="checkbox"/> MASTER <input checked="" type="checkbox"/> AMEX <input type="checkbox"/>	TOTAL LABOR....	199.97
DISCOVER <input type="checkbox"/> CARTE BLANCE <input type="checkbox"/> DINERS <input type="checkbox"/>	TOTAL PARTS....	24.01
CHECK# <input type="checkbox"/> CASH <input type="checkbox"/> CAR CARE ONE <input type="checkbox"/>	TOTAL SUBLET...	0.00
CHICAGO LICENCE NUMBERS 00535038 AND 00535852	TOTAL S.O.G....	0.00
SERVICE DEPARTMENT HOURS	TOTAL MISC CHG.	3.98
MONDAY THROUGH FRIDAY 7:00AM TO 6:00PM	TOTAL MISC DISC	0.00
SATURDAY 8:00 TO 4:00PM	TOTAL TAX.....	2.52
	TOTAL INVOICE \$	230.48

030075

[REDACTED SIGNATURE]

Thank You For Choosing Z Frank!

PLEASE SEE REVERSE SIDE FOR ADDITIONAL WARRANTY INFORMATION
END OF INVOICE

FORM ERA-2 INV