

August 30, 2007



Dear Mr. J. Smith: 2007 DEC 13 AM 10:37

My RVC unit appear in the list that you submitted. Please, help me to repair it as soon as possible. Thank you.

Sincerely,

CL-10212756-4925



10/13/07
KJ



Mr. Daniel C. Smith
Associate Administrator for Enforcement
National Highway Traffic Safety Administration
400 Seventh Street, SW
Washington, DC 20590

Re: Defect Information Report; Vehicles Equipped with
Certain Refrigerators Manufactured by Dometic Corporation

Dear Valued Customer:

This notice is sent to you in accordance with the requirements of the National Highway Traffic and Motor Vehicle Safety Act.

Dometic Corporation has decided that a defect which related to motor vehicle safety exists on some of the refrigerators that it manufactured between April 1997 and May 2003 for installation in recreational vehicles.

Coachmen Recreational Vehicle Company, LLC (Coachmen RV) has been advised by Dometic Corporation that certain Dometic refrigerators installed as original equipment in some of **Coachmen's** recreational vehicles may contain a defect that relates to motor vehicle safety because they may experience a leak of pressurized coolant solution which can result in a vehicle fire under certain specific circumstances. On the basis of that Dometic determination, **Coachmen RV** has decided that there may be a potential safety defect in its vehicles equipped with the identified refrigerators, and we are therefore submitting the enclosed Defect Information Report pursuant to 49 CFR Part 573.

A complete listing of the affected Coachmen vehicle models is enclosed as attachment "A" with this letter.

If you have any questions, please do not hesitate to contact Coachmen Customer Service at 1-800-453-6064.

Sincerely,

Coachmen Recreational Vehicle Company, LLC

ATTACHMENT "A"

Coachmen RV, Georgie Boy Manufacturing and Shasta Recreational Vehicles potentially affected by Dometic Refrigerator Recall

<u>Model Year</u>	<u>Make</u>	<u>Model</u>
1997	COACHMEN	CATALINA
1997	GEORGIE BOY	CRUISE AIR
1997	GEORGIE BOY	CRUISE MASTER
1997	GEORGIE BOY	SWINGER
1997	GEORGIE BOY	ENCOUNTER
1997	COACHMEN	LEPRECHAUN
1997	COACHMEN	LITE
1997	GEORGIE BOY	MAVERICK
1997	COACHMEN	MIRADA
1997	GEORGIE BOY	PURSUIT
1997	COACHMEN	RANGER
1997	COACHMEN	ROYAL
1997	GEORGIE BOY	ROADRUNNER
1997	COACHMEN	SANTARA
1997	COACHMEN	SPORT
1997	GEORGIE BOY	SWINGER
1997	COACHMEN	ULTRA LITE
1998	COACHMEN	CATALINA
1998	GEORGIE BOY	CRUISE AIR
1998	GEORGIE BOY	CRUISE MASTER
1998	GEORGIE BOY	ENCOUNTER
1998	COACHMEN	FUTURA
1998	COACHMEN	LEPRECHAUN
1998	COACHMEN	LITE
1998	GEORGIE BOY	MAVERICK
1998	GEORGIE BOY	MAVERICK
1998	COACHMEN	MIRADA
1998	COACHMEN	PATHFINDER
1998	COACHMEN	PROSPERA
1998	GEORGIE BOY	PURSUIT
1998	COACHMEN	RANGER
1998	COACHMEN	ROYAL
1998	GEORGIE BOY	ROADRUNNER
1998	GEORGIE BOY	ROADRUNNER
1998	COACHMEN	SANTARA
1998	COACHMEN	SPORT
1998	GEORGIE BOY	SWINGER
1999	COACHMEN	CATALINA
1999	GEORGIE BOY	CRUISE AIR
1999	GEORGIE BOY	CRUISE MASTER
1999	COACHMEN	FUTURA
1999	GEORGIE BOY	LANDAU
1999	COACHMEN	LEPRECHAUN
1999	COACHMEN	LITE
1999	GEORGIE BOY	MAVERICK
1999	COACHMEN	MIRADA

1999	COACHMEN	PATHFINDER
1999	COACHMEN	PROSPERA
1999	GEORGIE BOY	PURSUIT
1999	COACHMEN	RANGER
1999	COACHMEN	ROYAL
1999	GEORGIE BOY	ROADRUNNER
1999	COACHMEN	SANTARA
1999	COACHMEN	SPORT
1999	COACHMEN	SPORTSCOACH
1999	COACHMEN	ULTRA LITE
2000	COACHMEN	CATALINA
2000	GEORGIE BOY	CRUISE AIR
2000	GEORGIE BOY	CRUISE MASTER
2000	COACHMEN	FUTURA
2000	GEORGIE BOY	LANDAU
2000	COACHMEN	LEPRECHAUN
2000	COACHMEN	LITE
2000	GEORGIE BOY	MAVERICK
2000	COACHMEN	MIRADA
2000	COACHMEN	PATHFINDER
2000	COACHMEN	PROSPERA
2000	GEORGIE BOY	PURSUIT
2000	COACHMEN	RANGER
2000	COACHMEN	ROYAL
2000	COACHMEN	SANTARA
2000	COACHMEN	SPORT
2000	GEORGIE BOY	SUITE
2001	COACHMEN	AURORA
2001	COACHMEN	CATALINA
2001	SHASTA	CHEYENNE
2001	GEORGIE BOY	CRUISE MASTER
2001	SHASTA	FLITE
2001	SHASTA	FREEPORT
2001	COACHMEN	FUTURA
2001	GEORGIE BOY	LANDAU
2001	COACHMEN	LEPRECHAUN
2001	COACHMEN	LITE
2001	GEORGIE BOY	MAVERICK
2001	COACHMEN	MIRADA
2001	COACHMEN	PATHFINDER
2001	SHASTA	PHOENIX
2001	COACHMEN	PROSPERA
2001	GEORGIE BOY	PURSUIT
2001	COACHMEN	RANGER
2001	COACHMEN	ROYAL
2001	COACHMEN	SANTARA
2001	SHASTA	SPRITE
2001	GEORGIE BOY	SUITE
2001	SHASTA	TRAVELMASTER
2002	COACHMEN	AURORA
2002	COACHMEN	CAPTIVA
2002	COACHMEN	CASCADE
2002	COACHMEN	CATALINA
2002	COACHMEN	CHAPARRAL

2002	SHASTA	CHEYENNE
2002	COACHMEN	CHEYENNE
2002	COACHMEN	CROSSCOUNTRY
2002	GEORGIE BOY	CRUISE AIR
2002	GEORGIE BOY	CRUISE MASTER
2002	SHASTA	FREEPORT
2002	COACHMEN	FREEPORT
2002	GEORGIE BOY	LANDAU
2002	COACHMEN	LEPRECHAUN
2002	COACHMEN	LITE
2002	GEORGIE BOY	MAVERICK
2002	COACHMEN	MIRADA
2002	SHASTA	OASIS
2002	COACHMEN	OASIS
2002	COACHMEN	PATHFINDER
2002	GEORGIE BOY	PURSUIT
2002	GEORGIE BOY	REBEL
2002	SHASTA	REVERE
2002	COACHMEN	SANTARA
2002	SHASTA	SHASTA
2002	COACHMEN	SHASTA
2002	COACHMEN	SOMERSET
2002	COACHMEN	SPIRIT OF AMERICA
2002	SHASTA	SPRITE
2002	COACHMEN	SPRITE
2002	GEORGIE BOY	SUITE
2003	COACHMEN	AURORA
2003	COACHMEN	AURORA GOLD
2003	COACHMEN	CAPTIVA
2003	COACHMEN	CASCADE
2003	COACHMEN	CATALINA
2003	COACHMEN	CHAPARRAL
2003	COACHMEN	CHEYENNE
2003	COACHMEN	COACHMEN LTS
2003	GEORGIE BOY	CRUISE AIR
2003	GEORGIE BOY	CRUISE MASTER
2003	COACHMEN	FREEDOM
2003	COACHMEN	FREEPORT
2003	GEORGIE BOY	LANDAU
2003	COACHMEN	LEPRECHAUN
2003	COACHMEN	MIRADA
2003	COACHMEN	OASIS
2003	COACHMEN	PATHFINDER
2003	GEORGIE BOY	PURSUIT
2003	COACHMEN	RENDEZVOUS
2003	SHASTA	REVERE
2003	COACHMEN	REVERE
2003	COACHMEN	SAFARI
2003	COACHMEN	SANTARA
2003	COACHMEN	SHASTA
2003	SHASTA	SHASTA SE
2003	COACHMEN	SOMERSET
2003	COACHMEN	SOMERSET DC
2003	COACHMEN	SPIRIT OF AMERICA

2003	COACHMEN	SPRITE
2003	COACHMEN	VELOCITY
2003	GEORGIE BOY	VELOCITY
2004	COACHMEN	AURORA
2004	GEORGIE BOY	BELLAGIO
2004	COACHMEN	CAPRI
2004	COACHMEN	CAPTIVA
2004	COACHMEN	CASCADE
2004	COACHMEN	CATALINA
2004	COACHMEN	CHAPARRAL
2004	COACHMEN	CHEYENNE
2004	COACHMEN	CONCORD
2004	COACHMEN	CROSSCOUNTRY
2004	GEORGIE BOY	CRUISE AIR
2004	GEORGIE BOY	CRUISE MASTER
2004	COACHMEN	FREEDOM
2004	COACHMEN	FREELANDER
2004	COACHMEN	FREEPORT
2004	GEORGIE BOY	LANDAU
2004	COACHMEN	LEPRECHAUN
2004	COACHMEN	MIRADA
2004	COACHMEN	OASIS
2004	GEORGIE BOY	PURSUIT
2004	COACHMEN	RENDEZVOUS
2004	COACHMEN	REVERE
2004	COACHMEN	ROADMASTER
2004	COACHMEN	SANTARA
2004	COACHMEN	SOMERSET DC
2004	COACHMEN	SPIRIT OF AMERICA
2004	GEORGIE BOY	VELOCITY
2005	GEORGIE BOY	BELLAGIO
2005	COACHMEN	CAPRI
2005	GEORGIE BOY	CRUISE AIR
2005	GEORGIE BOY	CRUISE MASTER
2005	GEORGIE BOY	CRUISE MASTER
2005	GEORGIE BOY	LUXURA
2005	GEORGIE BOY	LANDAU
2005	GEORGIE BOY	PURSUIT
2005	GEORGIE BOY	VELOCITY



IMPORTANT

Dometic Recall Information

SERIAL NUMBER/GAS VALVE INSTRUCTIONS

RECALL 06E-076

Where to find the serial and model numbers on your Dometic refrigerator

The serial and model numbers are both located on a sticker inside the fridge door. *It could be on either side of the interior.*

Remember, the model number starts with RM or NDR, and the serial number is 8 digits long.

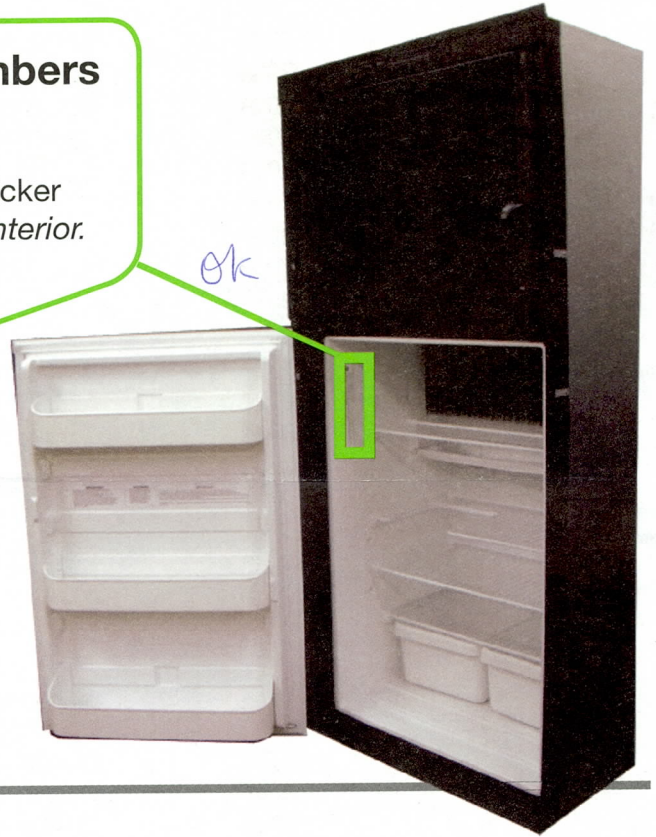

How to close the gas valve on your Dometic refrigerator

The manual gas valve is located at the back of your refrigerator near the floor as seen in the diagram to the left. Access the back of your refrigerator by removing the vent on the side of your coach. The vent will look like one of the two following illustrations:

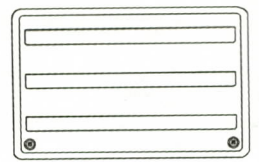
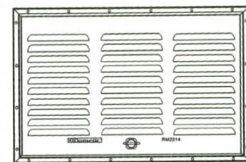
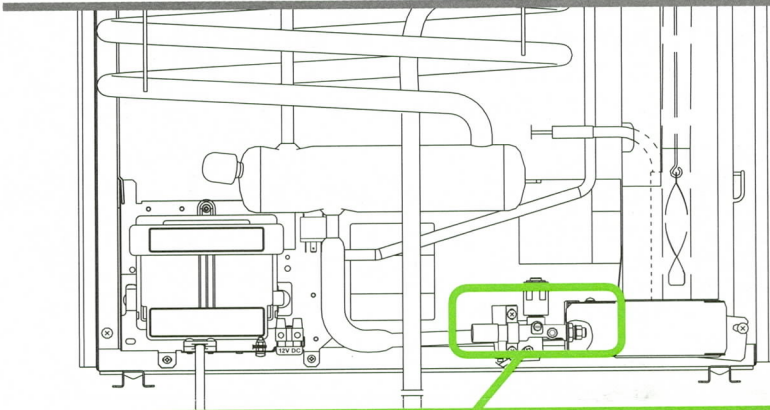

The gas valve is opened and closed by adjusting a screw. To close the valve, use either your fingers or a flat-head screwdriver to turn the screw 1/4 turn clockwise.

The valve is closed if the flathead slot in the screw runs up and down. The valve is still open if the flathead slot in the screw runs side to side.

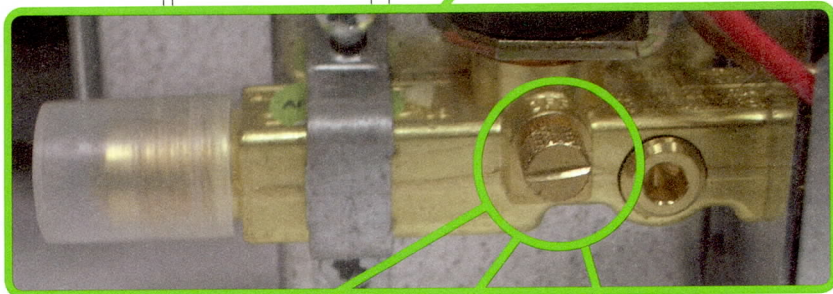

Open



Turn Clockwise

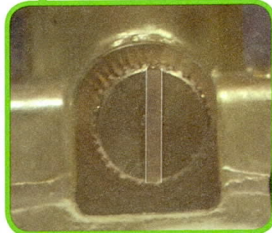

Closed OK



RE: Dometic Refrigerator Recall

Dear Valued Customer:

This notice is sent to you in accordance with the requirements of the National Highway Traffic and Motor Vehicle Safety Act.

Dometic Corporation has decided that a defect which related to motor vehicle safety exists on some of the refrigerators that it manufactured between April 1997 and May 2003 for installation in recreational vehicles.

The Problem:

A fatigue crack can develop in the boiler tube of the identified refrigerators, which can permit the release of pressurized coolant solution. If this solution is exposed to an ignition source under certain specific circumstances, it can result in a vehicle fire.

Affected Units:

The potentially affected refrigerators have the following model numbers:

NDR1062, RM2652, RM2662, RM2663, RM2852, RM2862, RM3662, RM3663, RM3862, RM3863

The possibly affected units have serial numbers beginning with the following combinations:

- 713xxxxx through 752xxxxx
- 801xxxxx through 852xxxxx
- 901xxxxx through 952xxxxx
- 001xxxxx through 052xxxxx
- 101xxxxx through 152xxxxx
- 201xxxxx through 252xxxxx
- 301xxxxx through 319xxxxx

2 3 5 0 3 9 6 8 # serial

If you own one of the above units, it requires immediate service and continuing use could pose a potential safety hazard.

How Do I Know If My Refrigerator Is Being Recalled?

- 1) Find your refrigerator's model and serial numbers by opening the refrigerator door and looking for the sticker attached to the side wall of the interior. See the photo instructions included in this mailing for the exact location of the sticker.
- 2) Call **1-888-446-5157** or go to **www.DometicUSA.com** to confirm if your refrigerator is affected by the recall.

What To Do:

1) Turn the refrigerator off immediately if you notice any of the following indicators:

- Leakage or staining at the back of the refrigerator.
- Yellow residue at the back or sides of the refrigerator.
- The smell of ammonia.
- Refrigerator does not properly cool.

Any unit found to have one or more of the characteristics mentioned above MUST be shut down and not operated until the unit is fixed and the recall rework administered.

For any unit that does fall within the recall population, but does not exhibit any of the four indicators mentioned in #1, consider the following:

- 2) Do not operate your refrigerator on LP gas. Switching to electric power lowers the incident rate associated with LP gas. If you own a 3-way refrigerator, running the unit on 12-volt power carries the least risk of all. 3-way refrigerators have model numbers that end in "3".

Dometic recommends that the unit not be operated on electric unless absolutely necessary until your unit has been serviced. **If you choose to operate your unit on electric prior to the recall rework, you must inspect the burner area weekly for any of the indicators referenced in number 1 above.**

- 3) Dometic recommends that you turn off the gas valve at the back of your refrigerator. DO NOT, however, attempt to disconnect the gas supply. Instructions on how to turn off the gas valve are included in this envelope.
- 4) If you must operate your refrigerator on electric, DO NOT operate your refrigerator while in transit or while occupants are asleep.
- 5) The rework kit will be available on April 16, 2007. At that time, call your preferred service center to set up an appointment. For help in locating a service center, or for the most up-to-date recall information, call 1-888-446-5157.

Please do not simply go to a dealer or service center without an appointment, since some facilities will not be performing this work, and the ones that are doing the work will need to obtain the appropriate parts from us. Please bring this letter with you at the time of your scheduled service.

- 6) If the repair facility fails or is unable to rework this noncompliance without charge and within a reasonable time, please contact us at the number provided above so we can attempt to resolve the problem. You may also submit a written complaint to the Administrator, National Highway Traffic Safety Administration, 400 Seventh Street, SW, Washington, DC 20590; or call the toll-free Vehicle Safety Hotline at 1-888-327-4236 (TTY: 1-800-424-9153); or go to <http://www.safercar.gov>.

- 7) If you previously paid to repair or replace a Dometic refrigerator that failed due to this defect, you can be reimbursed for your costs pursuant to Dometic's Pre-Notification Reimbursement Program. To be eligible for reimbursement under that Program, you must complete and submit the required form and provide the necessary documentation. The Program and form can be obtained by calling 1-888-446-5157.

If You No Longer Own This Refrigerator:

If you are no longer the owner of the affected refrigerator, we would greatly appreciate you furnishing us with the name and address of the new owner by calling 1-888-446-5157.

You May Receive More Than One Mailing In Regards To The Recall:

To reach as many customers as possible, Dometic and the original manufacturer of your RV will each send notifications in regards to this recall. Be advised that though you may receive multiple notifications, all pertain to this same, single recall.

On a Personal Note:

We sincerely apologize for any inconvenience this may cause. We are continually committed to developing innovative products to meet your needs and enhance your RV travels, keeping your safety at the top of our priority list.

Patrick N. McConnell
Director of Engineering, Product Safety and Standards
Dometic Corporation

RECALL 06E-076