

10157324

2006 MAY -1 PM 3: 24
Hillsborough, NJ

April 25, 2006

US Department of Transportation
The National Highway Traffic Safety Administration
Office of Defect Investigation
N.S.A.-10.01, 400 7th Street, SW
Washington, DC 20590

Dear Sirs,

This is to advise you of a safety issue related to my 1993 Chrysler Town & County Mini Van.

I have attempted to have the anti lock brake system repaired 10 times spending \$1,500 but the system continues to fail making the vehicle dangerous and unusable. I have had it diagnosed twice at the dealer but they could not remedy the problem advising the problem could be not determined and /or not repairable.

My non dealer mechanic has tried in vain to reach the cause for failure and provided me with the NHTSH safety bulletin.

I am attaching all documentation sent to dealer and Chrysler.

Thank you for your attention.

Sincerely yours,

RNP/del

Mani
5/3/06

April 25, 2006

Daimler Chrysler Corporation
Chrysler Relations Manger
Northeast Business Center
108 Routes 303
Tappan, NY 10983

Dear Sirs,

I am [REDACTED] who lives at [REDACTED], Hillsborough, NJ [REDACTED]. [REDACTED]
[REDACTED] I own a 1993 Chrysler Town & Country. I have developed a severe and dangerous
brake problem that has not been able to be repaired even by one of your dealers.

The VIN #31C4GH54R6PX [REDACTED], file reference #14271852.

In November of 2005 I spoke with several Chrysler people relating my situation to them.
I was advised to seek remedy from my local authorized dealer. I have done that but my
problem still exists.

I have spent \$1,501.00 to correct the problem to no avail. As this is a safety issue I have
to pursue a remedy until a satisfactory solution is reached.

I have had the major components in the system repaired, changed, tested, retested but the
brake system still fails.

I am attaching a chronology of repairs for your review. With as many units sold by
Chrysler I would think my problem is not the only system that has failed out of several
hundred thousand.

I am also advising the NHTSA of this problem.

Please contact me for additional details. Thank you for you consideration.

Sincerely yours,

[REDACTED]

RNP/del
Cc. NHTSA

November 14, 2005

[REDACTED]
[REDACTED]
Hillsborough, NJ [REDACTED]

Home [REDACTED]
Work [REDACTED]

Vehicle: 1993 Chrysler Town & Country, Dark Green
License Number PKC88P

Problem: ABS System Mal function. 4 repair attempts have failed to correct the ABS mal function.

Alerted when Information Center Indicators for the ABS and Brake Warning Lights illuminate and do not turn off. In addition the brake pedal becomes difficult to depress. As driving an auto with mechanical brakes.

History:

12/30/03 ABS failure. Replaced accumulator and remanufactured pump motor assembly

09/23/05 ABS failure, checked out system as system failed again. Repaired connection At relay.

10/20/05 System failure again. Replaced relay for ABS.

10/21/05 System Failure again. Replace ABS Pump as previously done on 12/30/03

11/03/05 to 11/08/05 System Failure again. Discovered NHTSA RECALL BULLETIN.

System seems to fail when in traffic. If while driving the brake pedal is depressed rapidly several times (5-10 times) the warning lights indicate system is about to fail, and does.

This report is for informational purposes and history of attempted repairs and/or remedies.

1/11/05 DIAGNOSED AT BELLE MEAD GAR. REPLACE ACCUMULATOR.

1/17/05 ACCUMULATOR REPLACED - DID NOT SOLVED PROBLEM.

12/30/05 RETRIEVED AUTO - BILL DENSON COULD NOT SOLVE PROBLEM

JAN 5/2006 RETURNED AUTO TO BELLE MEAD GAR WITH REPAIR HISTORY FOR RE-EVALUATION. PROVIDED BENDIX-10 ABS WIRE DIAGRAM FOR SYS. OVERVIEW.

2/8/06 AUTO RETURNED - NO ADDITIONAL PROBLEM DISCOVERED EXCEPT FUSE FROM DEALER - BELLE MEAD GAR (BELLE MEAD NJ) 0802 - SYSTEM FAILED.

1993 Chrysler Town & Country

ABS FAILURE - REPAIR/REPLACE/REIMBURSE PREVIOUS WORK NHTSA RECALL BULLETIN

ABS FAILURE - REPAIR/REPLACE/REIMBURSE PREVIOUS WORK

NHTSA RECALL BULLETIN

Reference Number(s): 96V099000

VEHICLE DESCRIPTION

Model(s): 1990-93 Chrysler Imperial

1990-93 Chrysler New Yorker

1990-93 Dodge Dynasty

1991-93 Chrysler Town & Country

1991-93 Dodge Caravan

1991-92 Dodge Monaco

1991-92 Eagle Premier

1991-93 Plymouth Voyager Campaign No.: 96V099000

Number of Affected Vehicles: 321000

Beginning Date of Manufacture: 1990 JUL

Ending Date of Manufacture: 1993 JUN

Passenger vehicles and mini-vans equipped with anti-lock brake systems (ABS).

SYSTEM

Brakes; hydraulic; anti-skid system.

FAULT

Chafes, Excessive wear, Scored

DESCRIPTION OF DEFECT

The ABS hydraulic control unit can experience excessive brake actuator piston seal wear causing pump-motor deterioration.

CONSEQUENCE OF DEFECT

If this condition occurs, the ABS function could be lost and reduced power assist would be experienced during vehicle braking increasing the potential for a vehicle accident.

CORRECTIVE ACTION

Dealers will test the vehicle's anti-lock brake system and repair the vehicles if necessary. Also the warranty on all ABS components will be extended to 10 years or 100,000 miles (except for the brake actuator piston assembly and the pump-motor assembly which will have a lifetime coverage). Owners will also be reimbursed for previous ABS component repair costs.

NOTE

Owners who take their vehicles to an authorized dealer on an agreed upon service date and do not receive the free remedy within a reasonable time should contact Chrysler at 1-800-853-1403. Also contact the National Highway Traffic Safety Administration's Auto Safety Hotline at 1-800-424-9393.

ADDITIONAL INFORMATION

800-992-1997 CHRYSLER.

The National Highway Traffic Safety Administration operates Monday through Friday from 8:00 AM to 4:00 PM, Eastern Time. For more information call (800) 424-9393 or (202) 366-0123. For the hearing impaired, call (800) 424-9153.

NHTSA.COM

4/11/05

1:55 PM KIM @ NHTSA - CALL BACK FILE A COMPLAINT IF NO SATISFACTION.

200 800-992-1997 2:55 *A PERSON - AARON.

CONTACT US @

CHRY.COM 1-800-853-1403

0:00 AM AARON - COMPUTER AS DOWN - CALL BACK 11/11/05

1:30 WALTER - COMP - STUCK DOWN.

1:00 RACHAEL - VIN - 3 1C4 @ HSARB PK699193 - COLLECTED PERSONAL INFO INCL. DEALER INFO.

ROBT - FILE # REF# 14271852 →

LINDSEY → "GOOD WILL DEPT" →

3:5 ASHLEY → ON HOLD TO REPAIR. WILL CALL BELLEVUE GARAGE - IF NOT DONE THROUGH DANA CHRY CENTER. THERE IS NO REIMBURSEMENT. ACCORD IF PART THAT NEEDS TO BE REPAIRED.

Denson Auto Repair

Tuesday, November 08, 2005 11:25:02 AM

Page 2

© 2004 Mitchell Repair Information Company, LLC.

ANTI-LOCK - BENDIX-10

Johnson Auto Repair
32 Rt 208 South
Somerville, NJ 08878

Fig. 20: Bendix-1L JS Wiring Diagram
1993 Chrysler Town & Country

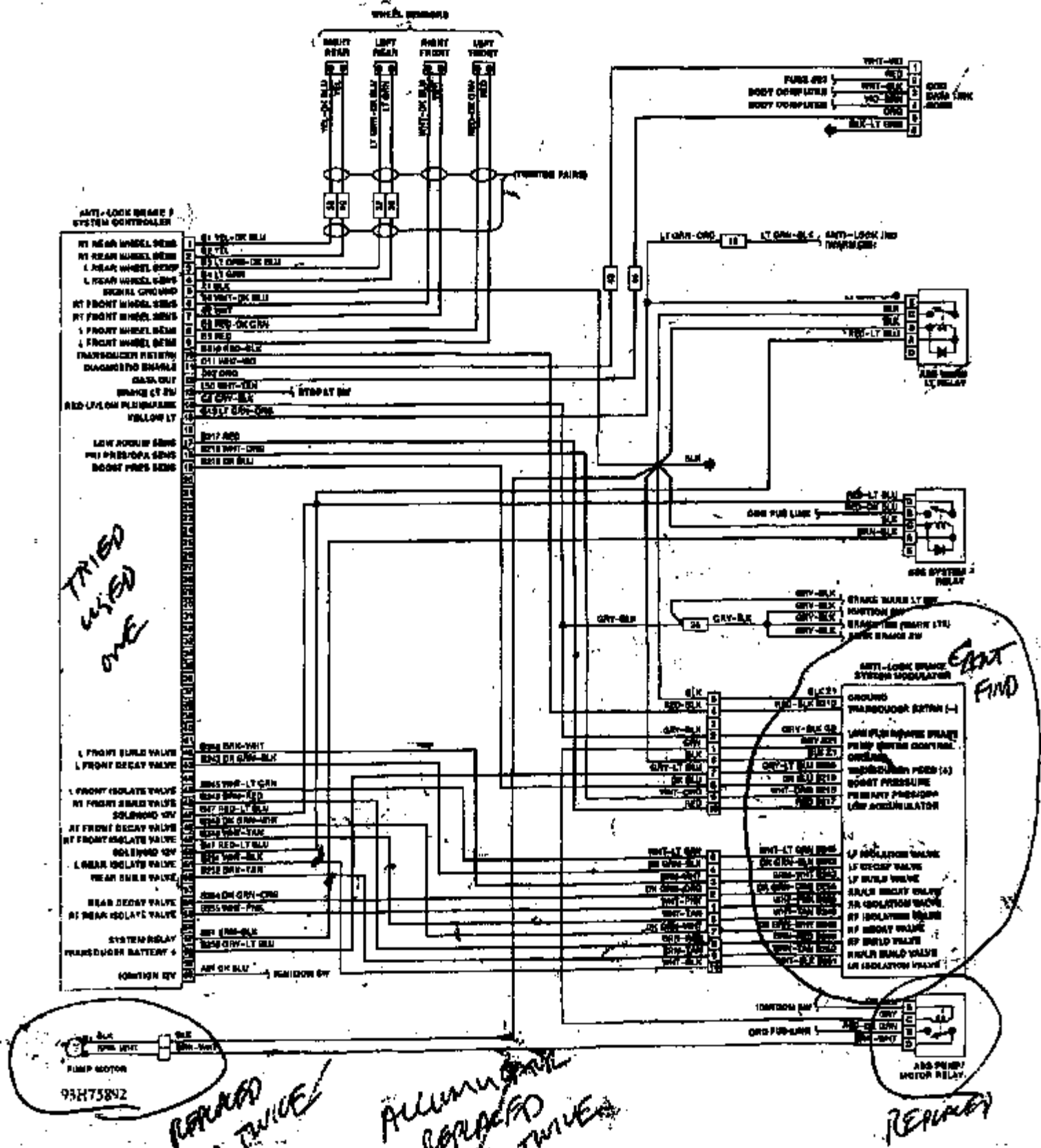

**THE ATTACHMENTS TO THIS
DOCUMENT HAVE BEEN REMOVED
TO PROTECT UNWARRANTED
INVASION OF PERSONAL PRIVACY
PURSUANT TO EXEMPTION 6 OF
THE FREEDOM OF INFORMATION
ACT (FOIA), 5 U.S.C. 552(b)(6).**