



U.S. Department of Transportation
National Highway Traffic Safety Administration

DOT Auto Safety Hotline

Vehicle Owner's Questionnaire
To Report Vehicle Safety Defects
1-888-DASH-2-DOT
(1-888-327-4236)
INTERNET www.nhtsa.dot.gov/hotline

FOR AGENCY USE ONLY 100147

Date Received
2003 AUG 22 AM 9:13
29-JUL-2003

Repository
Reference No.
10031321

OWNER INFORMATION (Type or Print)

Name [Redacted]
Address [Redacted]
City EL DORADO HILLS State CA Zip Code [Redacted]

Daytime Telephone Number [Redacted] Email Address [Redacted]
Evening Telephone Number [Redacted]

Do you authorize NHTSA to provide a copy of this report to the manufacturer of your vehicle? YES NO
In the absence of an authorized signature, provide your name or address to the vehicle manufacturer.
Signature of Owner [Redacted] Date 8/6/03

VEHICLE INFORMATION

17 digit Vehicle Identification Number Located at bottom of windshield on driver's side: 456CK5B6W6W [Redacted]
Make HONDA Model PASSPORT Model Year 1998
Date Purchased 8/15/98 Dealer's Name and Telephone Number Honda of Yorba Linda
Original Owner Dealer's City Yorba Linda State CA Zip Code 92687 Engine: V-6 No. Cylinders Fuel Type: unleaded
Transmission Type Automatic Antilock Brakes Cruise Control Powertrain 3.2 L DOHC 2 valve
Vehicle Component Code 980000 OTHER Multiple Failure: 1

FAILED COMPONENT(S)/PART(S) INFORMATION

Incident Date(s) 15-JUL-2003 Failure Mileage 30 Failure Speed 0

ADDITIONAL ITEMS TO BE COMPLETED WHEN REPORTING A TIRE FAILURE

The Make [Redacted] Tire Model (Name or Number) [Redacted] Tire Size (Example P215/65R15) [Redacted]
DOT No. (Example: DOTM4L9A8C036) Original Equipment Prior Repair Failure Location: [Redacted]
Tire Component Code [Redacted] Tire Failure Type [Redacted]

ADDITIONAL ITEMS TO BE COMPLETED WHEN REPORTING A CHILD SEAT FAILURE

Make: [Redacted] Date Manufactured: [Redacted] Model No./Name: [Redacted]
Seat Type: [Redacted] Installation System: [Redacted]
Child Seat Component Code: [Redacted] Failed Part: [Redacted]

APPLICABLE INCIDENT INFORMATION

(Please describe in detail the incident(s), failure(s), condition, and injury(ies).)

Crash Yes No Fire Yes No Number of Persons Injured 1 Number of Deaths 0 Reported to Police N

Narrative Description of Incident(s), Crash(es), and Injury(ies).
Please describe (1) events leading up to the failure, (2) failure and its consequences, and (3) what was done to correct the failure; i.e., parts repaired or replaced (and if old part is available).

CONSUMER STATES THAT REAR CUP HOLDER KEEPS OPENING UP, CAUSING THE KIDS IN THE BACK SEAT TO TRIP OVER THE CUP HOLDER. DEALER NOTIFIED. *AK

Rear cup holder has not worked properly since the car was purchased. Told by one salesperson that this was a defect on all Aspirets. Eventually, the problem got worse and worse and the cupholder opens up on its own. Our three year old daughter has tripped over it on numerous occasions, resulting in scrapes and scratches to her leg. I researched the problem and came across Honda Technical Service Bulletin 98-027 (retained) which describes

Include, if available: Police/Fire Department Report, Photos, and Repair Invoice. ATTACH ADDITIONAL SHEETS IF NECESSARY

The Privacy Act of 1974 (Public Law 93-579) This information is requested pursuant to authority vested in the National Highway Traffic Safety Act and subsequent amendments. You are under no obligation to respond to this questionnaire. Your response may be used to assist the NHTSA in determining whether a manufacturer should take appropriate action to correct a safety defect. If the NHTSA proceeds with administrative enforcement or litigation against a manufacturer, your response, or a statistical summary thereof, may be used in support of the agency's action.

Narrative Description of Incident(s), Failure(s), Crash(es), and Injury(ies)

The problem I'm having and the corrective action that needs to be done to fix it. The bulletin states that when the problem is brought to their attention during warranty, it should be fixed for free, outside of warranty, at Honda's discretion. This bulletin covers my VIN number and was received since my car. I read across the bulletin only partly while searching your website. I called the dealer to fix it for free and was refused to compensate. I sent corporate Honda a letter and (attached) and they refused to fix the problem (letter also attached).

ATTACH ADDITIONAL SHEETS IF NECESSARY

US Department of Transportation

National Highway Traffic Safety Administration

400 Seventh St., S.W. Washington, D.C. 20590

Official Business Penalty for Private Use \$300



NO POSTAGE NECESSARY IF MAILED IN THE UNITED STATES

BUSINESS REPLY MAIL

FIRST CLASS PERMIT NO 73173 WASHINGTON, D.C.

POSTAGE WILL BE PAID BY NATL. HWY. TRAFFIC SAFETY ADMIN.

U.S. Department of Transportation
National Highway Traffic Safety Administration
Office of Defects Investigation, NVS-216
400 7th Street, SW
Washington, DC 20590



VEHICLE OWNER'S QUESTIONNAIRE

DOT AUTO SAFETY HOTLINE

TO REPORT VEHICLE SAFETY DEFECTS
COMPLETE THIS FORM
OR

DASH2DOT

and dial toll free at

1-888-DASH-2-DOT

1-888-327-4236

DOT Auto Safety Hotline
(DASH) & DOT

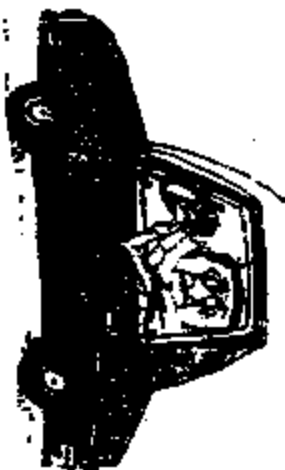

US Department of Transportation
National Highway Traffic Safety Administration
<http://www.nhtsa.dot.gov/defects>



Applies To: 1998 Passport - ALL

May 11, 1999

Rear Beverage Holder Will Not Stay Closed (Supersedes 98-027, dated May 5, 1998)

SYMPTOM

One or both of the magnetic latches do not hold the rear beverage holder closed.

PROBABLE CAUSE

The metal striker plate does not stay bonded to the plastic, or the cover is not flat.

CORRECTIVE ACTION

Replace the rear console cover.

PARTS INFORMATION

Rear Console Cover:
P/N 8-97198-421-0, H/C 5903828

WARRANTY CLAIM INFORMATION

In warranty: The normal warranty applies.

Operation number: 044-101

Flat rate time: 0.3 hour

Failed part: P/N 2-90002-801-0
H/C 5693650

Defect code: 018

Contention code: A02

Template ID: 98-027A

Skill level: Repair Technician

Out of warranty: Any repair performed after warranty expiration may be eligible for goodwill consideration by the District Service Manager or your Zone Office. You must request consideration, and get a decision, before starting work.

REPAIR PROCEDURE

1. Remove the rear console assembly:

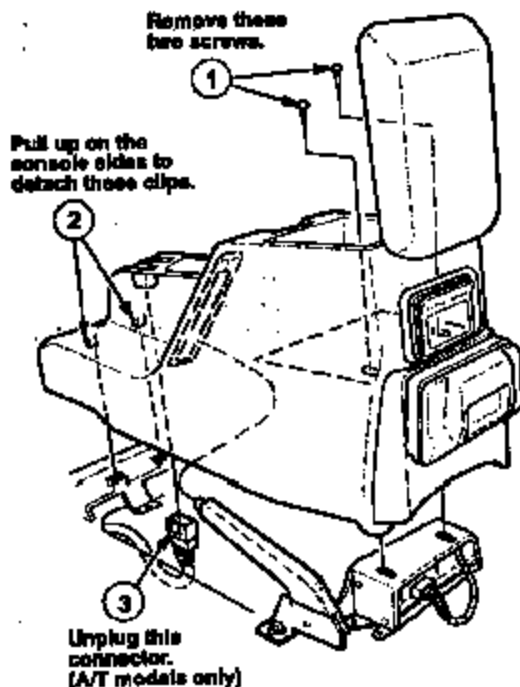

July 21, 2003

[REDACTED]
El Dorado Hills, CA [REDACTED]

American Honda Motor Company
Honda Automobile Customer Service
1919 Torrance Boulevard
Mail Stop: 500-2N-7D
Torrance, CA 90501-2746

To whom it may concern:

This letter is to complain about the lack of service I recently received when speaking to a customer service representative. I purchased my Passport in August of 1998. Since it was purchased, my rear beverage holder failed to stay closed. The dealer stated that, "it is just the way it was designed." The strike plate seems to fail to make proper contact with the magnet. On numerous occasions, my three-year old daughter has tripped upon this beverage holder. Last year, my fuel gauge started to work intermittently, not reading full when full, dropping to empty when the tank was full, and finally, not moving off of empty. As a matter of fact, I brought my car into my local dealer to have my air conditioning system checked and the technician mentioned to me that he couldn't take my car for as long of a test drive as intended because my "tank was empty." I told the technician ahead of time that the fuel gauge didn't work.

I came across two Honda Technical Service Bulletins that cover these problems. The first, Bulletin 98-027 was issued on May 11, 1999 and covers all 1998 Passports. It describes the symptom that I am experiencing - one or both of the magnetic latches do not hold the rear beverage holder closed. In addition, it describes the corrective action as replacing the rear console cover. If discovered during the warranty period, the bulletin allows the repair to be made for free. If discovered outside of warranty, the bulletin requires the District Service Manager or Zone Office to give consideration before work is to begin. The second, Technical Service Bulletin 99-004, was issued on September 14, 1999 and covers cars through VIN number 4S6C.58W.W4424533. My VIN number is 4S6CK58W6W4[REDACTED] so this bulletin covers my car. It too describes the symptoms I've experienced and states that the probable cause is "the resistance value at the fuel sending unit does not coincide with the fuel level in the tank." It goes on to state that the old fuel sending unit should be replaced with a new fuel sending unit with a higher resistance. In addition, the bulletin says that the PCM software should be updated according to Service Bulletin 99-005. These bulletins also require the intervention of the District Service Manager or Zone Manager to receive goodwill.

I brought these technical service bulletins to the attention of my local dealer, Shingle Springs Honda, and they recommended contacting Honda Customer Service. Customer Service told me that only recalls are free and that they the customer is always notified of recalls. I told the customer service representative that the technical service bulletins

clearly state that Honda was aware of the problems with these two components in 1999 and I requested goodwill from Honda. The customer service representative stated that since I received goodwill from Honda once, related to another technical service bulletin, I could not receive another.

I am again asking that Honda take responsibility for its mistakes and extend me goodwill. I am including the two technical service bulletins mentioned as well as a complaint that I have lodged with the Better Business Bureau. Thank you for your consideration in this matter.

Sincerely,



attachments

July 31, 2003



[REDACTED]
El Dorado Hills, CA [REDACTED]

Re: 1998 Honda Passport
VIN 4S6CK58W6W4 [REDACTED]

Dear [REDACTED]

This is in response to your contact to our office regarding your recent request for assistance with repair on your referenced Honda vehicle.

The Honda Customer Service office is set up to review individual customer concerns on a case-by-case basis. Under the terms of your Honda New Vehicle Limited Warranty and Honda Parts Warranty the Honda Automobile Division will repair or replace, at our option, any factory-installed part that is defective in manufacturing materials and/or manufacturing workmanship during the warranty period. The limits of your Honda New Vehicle Limited Warranty period were 3 years/36,000 miles, whichever occurred first. The limits of the Honda Parts Warranty period were 12 months/12,000 miles.

This matter has been reviewed by all pertinent personnel and it was determined we will be unable to offer any assistance. While Honda, the manufacturer, makes every effort to review customer concerns on a case-by-case basis, we are certain that you must appreciate that there is a point at which any necessary repairs become the responsibility of the owner of the vehicle. There will be no goodwill assistance on this issue.

We recognize repairs are unwelcome at any time and apologize for the frustration and inconvenience involved with this matter.

We trust this confirms our position on this issue.

Sincerely,

SERVICE OPERATIONS
AMERICAN HONDA MOTOR CO., INC.

A handwritten signature in black ink, appearing to read 'Brian Philbin', written in a cursive style.

Brian Philbin
Automobile Customer Service

Honda Automobile Division